

Market Driven Systems (FRTN20)

Exercise 1

Introduction and Continuous Production Plants

Last updated: 2014

1. What are the three basic types of production processes? Give a short explanation of each of them.
2. What is every manufacturing process, regardless of process type, designed to accomplish?
3. Which of the three types of production processes has a predominance of fluid processing?
4. Which of the three types of production processes has an open-ended production run?
5. Which of the three production processes involves the assembly of pieces and parts?
6. Describe two main characteristics of batch processes?
7. Give an example of one industrial production sector for each of the three production types?
8. A chemical reactor is shown in Figure 1.

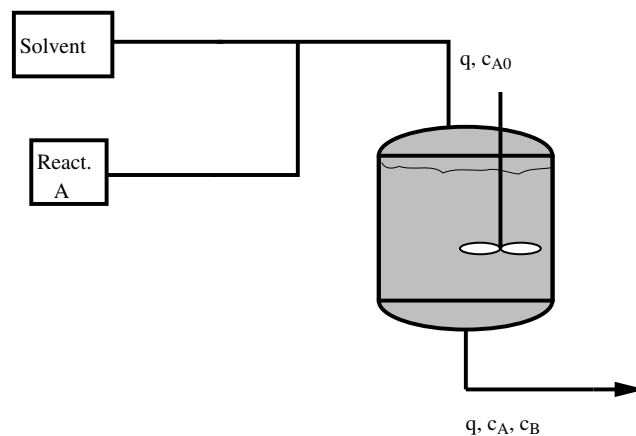

Figure 1 A reactor.

The chemical reaction, taking place in the reactor, is $A \rightarrow B$, with the reaction rate $r_A = -kc_A$. The overall objective is to control the concentration of substance B , c_B , in the reactor. The concentration c_B depends on the flow, q , through the reactor and the concentration of the inflow, c_{A0} .

Suggest how sensors, actuators, and controllers could be placed in order to control the flow, q , and the concentration, c_{A0} , to the reactor? The manipulated variables are the flow rates of the solvent and the reactant A .

9. A process section is shown in Figure 2, below. A simple exothermic reaction $A \rightarrow B$ takes place in the tank reactor (CSTR). The reactor feed is preheated, first by the hot reactor effluent and then by steam. Coolant, flowing through a jacket around the reactor, removes the heat generated by the reaction in order to maintain the temperature of the reacting mixture at the maximum allowable. The coolant is provided with two branches, one of which is cooled while the other is heated. The rates of cooling and heating are constant. With this configuration we can fine-tune the temperature of coolant before it enters the jacket of CSTR. The reactor effluent is first cooled by the feed in the feed effluent heat exchanger and subsequently it is flashed in the flash drum. There, it is separated into two streams, a vapor and a liquid, which are further processed in separate units. Cooling water is provided to regulate the temperature in the drum. Develop a process control system structure for the process.

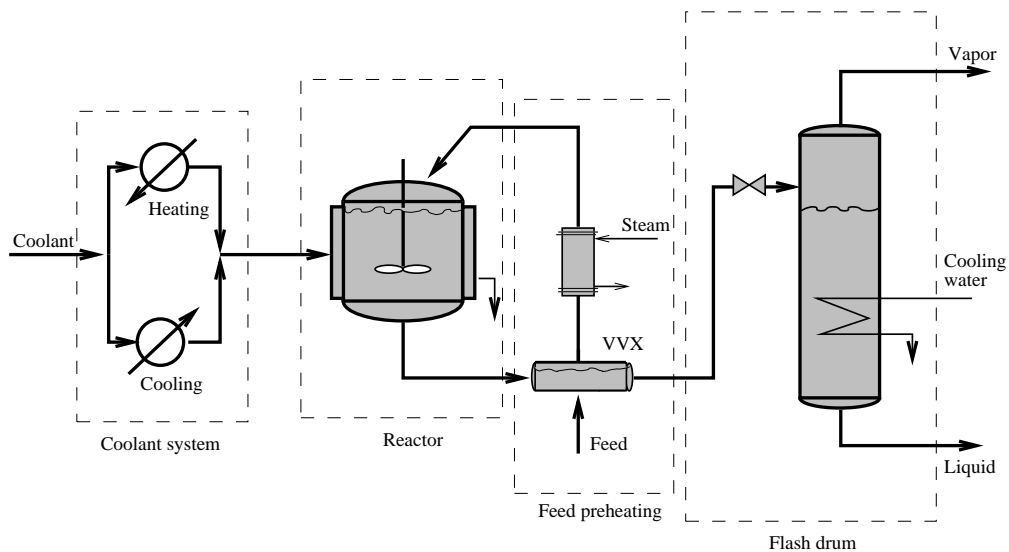

Figure 2 A chemical process.

- Select a production rate variable.
- Select corresponding inventory variables.
- Which additional variables must be controlled to guarantee production.
- How can product quality in the liquid outflow be controlled? Discuss.