

Exercises in Nonlinear Control Systems

Mikael Johansson

Bo Bernhardsson

Karl Henrik Johansson

Created: 1998

Latest update: November 9, 2017

Introduction

The exercises are divided into problem areas that roughly match the lecture schedule. Exercises marked “PhD” are harder than the rest. Some exercises require a computer with software such as Matlab and Simulink.

Many people have contributed to the material in this compendium. Apart from the authors, exercises have been suggested by Lennart Andersson, Anders Robertsson and Magnus Gäfvert. Exercises have also shamelessly been borrowed (=stolen) from other sources, mainly from Karl Johan Åström’s compendium in Nonlinear Control.

The authors, Jan 1999

Exercises marked with (H) have hints available, listed in the end of each chapter.

1. Nonlinear Models and Simulation

EXERCISE 1.1[KHALIL, 1996]

The nonlinear dynamic equation for a pendulum is given by

$$ml\ddot{\theta} = -mg \sin \theta - kl\dot{\theta},$$

where $l > 0$ is the length of the pendulum, $m > 0$ is the mass, $k > 0$ is a friction parameter and θ is the angle subtended by the rod and the vertical axis through the pivot point, see Figure 1.1.

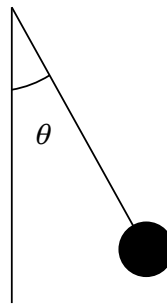

Figure 1.1 The pendulum in Exercise 1.1

- Choose appropriate state variables and write down the state equations.
- Find all equilibria of the system.
- Linearize the system around the equilibrium points, and determine if the system equilibria are locally asymptotically stable.

□

EXERCISE 1.2[KHALIL, 1996]

The nonlinear dynamic equations for a single-link manipulator, see Figure 1.2, with flexible joints, damping ignored, is given by

$$\begin{aligned} I\ddot{q}_1 + Mg \sin q_1 + k(q_1 - q_2) &= 0 \\ J\ddot{q}_2 - k(q_1 - q_2) &= u, \end{aligned}$$

where q_1 and q_2 are angular positions, I and J are moments of inertia, k is a spring constant, M is the total mass, L is a distance, and u is a torque input. Choose state variables for this system and write down the state equations.

□

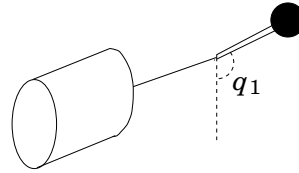

Figure 1.2 The flexible manipulator in Exercise 1.2

EXERCISE 1.3[KHALIL, 1996]

A synchronous generator connected to a strong electrical bus can be modeled by

$$M\ddot{\delta} = P - D\dot{\delta} - \eta_1 E_q \sin \delta$$

$$\tau \dot{E}_q = -\eta_2 E_q + \eta_3 \cos \delta + E_{FD},$$

where δ is the rotor deflection angle in radians, E_q is voltage, P is mechanical input power, E_{FD} is field voltage, D is damping coefficient, M is inertial coefficient, τ is a time constant, and η_1 , η_2 , and η_3 are constant parameters.

- (a) Using E_{FD} as input signal and δ , $\dot{\delta}$, and E_q as state variables, find the state equation.
- (b) Suppose that τ is relatively large so that $\dot{E}_q \approx 0$. Show that assuming E_q to be constant reduces the model to a pendulum equation with input torque.
- (c) For the simplified model, derived in (b), find all equilibrium points.

□

EXERCISE 1.4

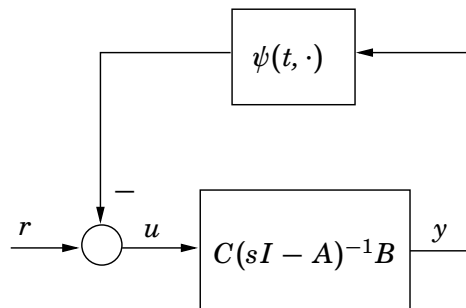

Figure 1.3 The feedback system in Exercise 1.4

Figure 1.3 shows a feedback connection of a linear time-invariant system and a nonlinear time-varying element. The variables r , u and y are vectors of the same dimension, and $\psi(t, y)$ is a vector-valued function.

- (a) Find a state-space model with r as input and y as output.
- (b) Rewrite the pendulum model from Exercise 1.1 into the feedback connection form described above.

□

EXERCISE 1.5[KHALIL, 1996]

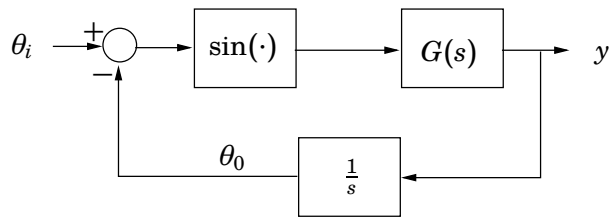

Figure 1.4 The phase-locked loop in Exercise 1.5

A phase-locked loop can be represented by the block diagram of Figure 1.4. Let $\{A, B, C\}$ be a state-space representation of the transfer function $G(s)$. Assume that all eigenvalues of A have negative real parts, $G(0) \neq 0$ and that θ_i is constant. Let z be the state of the realization $\{A, B, C\}$.

(a) Show that

$$\begin{aligned} \dot{z} &= Az + B \sin e \\ \dot{e} &= -Cz \end{aligned}$$

is a state equation for the closed-loop system.

(b) Find all equilibrium points of the system.

(c) If $G(s) = 1/(\tau s + 1)$, the closed-loop model coincides with the model of a pendulum with certain conditions on m, l, k , and g (as given in Exercise 1.1), what conditions?

□

EXERCISE 1.6 (H)

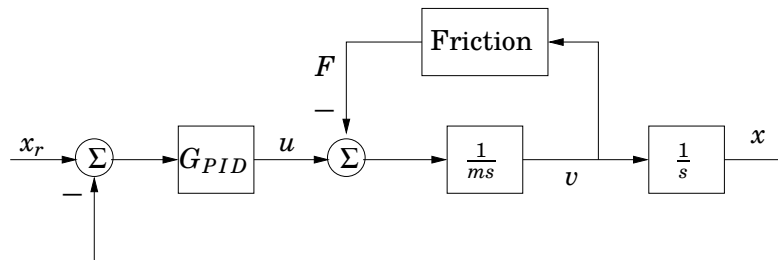

Figure 1.5 Control system with friction in Example 1.6.

Figure 1.5 shows a block diagram of a mechanical system with friction under PID control. The friction block is given by

$$F(v) = F_0 \text{sign}(v)$$

Let $x_r = 0$ and rewrite the system equations into feedback connection form (i.e. a linear system in feedback with a nonlinear system).

□

EXERCISE 1.7

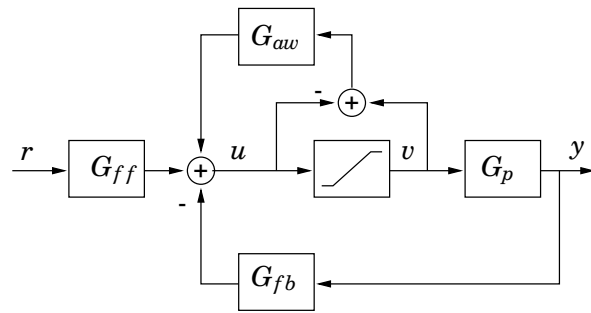

Figure 1.6 Anti-windup compensation in Example 1.7.

Figure 1.6 illustrates one approach to avoid integrator windup. Rewrite the system into feedback connection form.

□

EXERCISE 1.8

Consider the model of a motor with a nonlinear valve in Figure 1.7. Assume

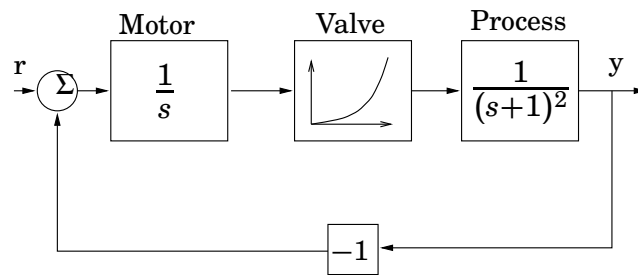

Figure 1.7 Block diagram of system in Exercise 1.8.

that the valve characteristic is given by $f(x) = x^2$ (this is unrealistic for $x < 0$).

- (a) Choose appropriate state variables and write down the state equations.
- (b) For which constant input amplitudes $r > 0$ does the system have a locally stable equilibrium?
- (c) What would be a more realistic valve model for $x < 0$?

□

EXERCISE 1.9

Is the following system (a controlled nonlinear spring) nonlinear locally controllable around $x = \dot{x} = u = 0$?

$$\ddot{x} = -k_1x - k_2x^3 + u.$$

□

EXERCISE 1.10^{PHD}

The equations for the unicycle in Figure 1.8 are given by

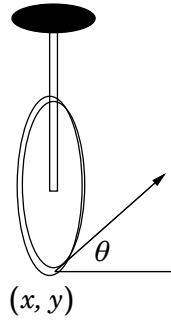

Figure 1.8 The “unicycle used in Exercise 1.10.

$$\begin{aligned} \dot{x} &= u_1 \cos \theta \\ \dot{y} &= u_1 \sin \theta \\ \dot{\theta} &= u_2, \end{aligned}$$

where (x, y) is the position and θ the angle of the wheel. Is the system nonlinear locally controllable at $(0, 0, 0)$? (*Hint*: Linearization gives no information; use the definition directly).

□

EXERCISE 1.11^{PHD}

The system in Figure 1.9 is known as the “rolling penny”. The equations are

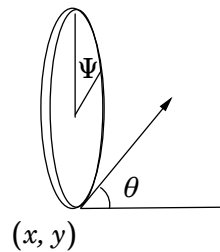

Figure 1.9 The “rolling penny” used in Exercise 1.11.

given by

$$\begin{aligned} \dot{x} &= u_1 \cos \theta \\ \dot{y} &= u_1 \sin \theta \\ \dot{\theta} &= u_2 \\ \dot{\Psi} &= u_1. \end{aligned}$$

Is the system nonlinear locally controllable at $(0, 0, 0, 0)$?

□

EXERCISE 1.12

Determine if the following system is nonlinear locally controllable at $(x_0, u_0) = (0, 0)$

$$\begin{aligned}\dot{x}_1 &= \cos(x_1) - 1 + x_2^2 + u \\ \dot{x}_2 &= \sin(x_1) + u^2.\end{aligned}$$

□

EXERCISE 1.13

Simulate the system $G(s) = 1/(s + 1)$ with a sinusoidal input $u = \sin \omega t$. Find the amplitude of the stationary output for $\omega = 0.5, 1, 2$. Compare with the theoretical value $|G(i\omega)| = 1/\sqrt{1 + \omega^2}$.

□

EXERCISE 1.14

Consider the pendulum model given in Exercise 1.1.

- Make a simulation model of the system in Simulink, using for instance $m = 1, g = 10, l = 1, k = 0.1$. Simulate the system from various initial states. Is the system stable? Is the equilibrium point unique? Explain the physical intuition behind your findings.
- Use the function `linmod` in Matlab to find the linearized models for the equilibrium points. Compare with the linearizations that you derived in Exercise 1.1.
- Use a phase plane tool (such as `pplane` or `pptool`, links at the course homepage) to construct the phase plane of the system. Compare with the results from (a).

□

EXERCISE 1.15

Simulate the example from the lecture with two tanks, using the models

$$\begin{aligned}\dot{h} &= (u - q)/A \\ q &= a\sqrt{2g}\sqrt{h},\end{aligned}$$

where h is the liquid level, u is the inflow to the tank, q the outflow, A the cross section area of the tank, a the area of the outflow and g the acceleration due to gravity, see Figure 1.10. Use a step input flow. Make a step change in u from $u = 0$ to $u = c$, where c is chosen in order to give a stationary value of the heights, $h_1 = h_2 = 0.1$. Make a step change from $u = c$ to $u = 0$. Is the process linear? Linearize the system around $h_1 = h_2 = 0.1$. Use $A_1 = A_2 = 3 \times 10^{-3}$, $a_1 = a_2 = 7 \times 10^{-6}$.

□

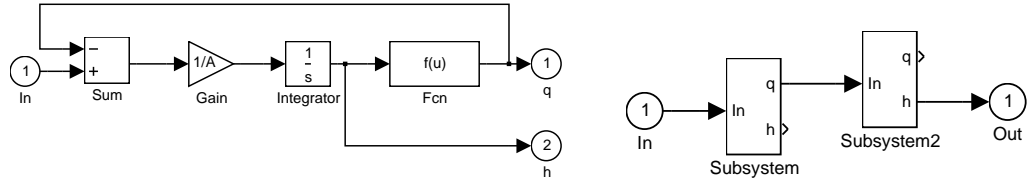

Figure 1.10 The flow system in Exercise 1.15

EXERCISE 1.16

Simulate the system with the the oscillating pivot point (the “electric hand-saw”), see Figure 1.11. Use the equation



Figure 1.11 The inverted pendulum on an electric hand-saw in Exercise 1.16

$$\ddot{\theta}(t) = \frac{1}{l}(g + a\omega^2 \sin \omega t)\theta(t).$$

Assume $a = 0.02m$ and $\omega = 2\pi \cdot 50$ for a hand-saw. Use simulation to find for what length l the system is locally stable around $\theta = \dot{\theta} = 0$ (Note: asymptotic stability is not required).

□

EXERCISE 1.17

The Lorentz equations

$$\begin{aligned} \frac{d}{dt}x_1 &= \sigma(x_2 - x_1) \\ \frac{d}{dt}x_2 &= rx_1 - x_2 - x_1x_3 \\ \frac{d}{dt}x_3 &= x_1x_2 - bx_3, \quad \sigma, r, b > 0, \end{aligned}$$

where σ, r, b are constants, are often used as example of chaotic motion.

- (a) Determine all equilibrium points.
- (b) Linearize the equations around $x = 0$ and determine for what σ, r, b this equilibrium is locally asymptotically stable.



Hints

Exercise 1.6

The nonlinear system in feedback with the friction block takes $-F$ as input and produces V . To find the linear system, treat $-F$ as input and V as output.

2. Linearization and Phase-Plane Analysis

EXERCISE 2.1[KHALIL, 1996] (H)

For each of the following systems, find and classify all equilibrium points.

- (a) $\dot{x}_1 = x_2$
 $\dot{x}_2 = -x_1 + x_1^3/6 - x_2$
- (b) $\dot{x}_1 = -x_1 + x_2$
 $\dot{x}_2 = 0.1x_1 - 2x_2 - x_1^2 - 0.1x_1^3$
- (c) $\dot{x}_1 = (1 - x_1)x_1 - 2x_1x_2/(1 + x_1)$
 $\dot{x}_2 = (1 - \frac{x_2}{1 + x_1})x_2$
- (d) $\dot{x}_1 = x_2$
 $\dot{x}_2 = -x_1 + x_2(1 - 3x_1^2 - 2x_2^2)$
- (e) $\dot{x}_1 = -x_1 + x_2(1 + x_1)$
 $\dot{x}_2 = -x_1(1 + x_1)$
- (f) $\dot{x}_1 = (x_1 - x_2)(x_1^2 + x_2^2 - 1)$
 $\dot{x}_2 = (x_1 + x_2)(x_1^2 + x_2^2 - 1)$

□

EXERCISE 2.2[ÅSTRÖM, 1968]

For all positive values of a , b and c , determine the equilibrium points of the system

$$\begin{aligned}\dot{x}_1 &= ax_1 - x_1x_2 \\ \dot{x}_2 &= bx_1^2 - cx_2\end{aligned}$$

and determine the type of equilibrium.

□

EXERCISE 2.3[KHALIL, 1996]

For each of the following systems, construct the phase portrait, preferably using a computer program, and discuss the qualitative behaviour of the system.

- (a) $\dot{x}_1 = x_2$
 $\dot{x}_2 = x_1 - 2 \tan^{-1}(x_1 + x_2)$
- (b) $\dot{x}_1 = x_2$
 $\dot{x}_2 = -x_1 + x_2(1 - 3x_1^2 - 2x_2^2)$
- (c) $\dot{x}_1 = 2x_1 - x_1x_2$
 $\dot{x}_2 = 2x_1^2 - x_2$

□

EXERCISE 2.4

Saturations constitute a severe restriction for stabilization of system. Figure 2.1 shows three phase portraits, each corresponding to one of the following linear systems under saturated feedback control.

- (a) $\dot{x}_1 = x_2$
 $\dot{x}_2 = x_1 + x_2 - \text{sat}(2x_1 + 2x_2)$
- (b) $\dot{x}_1 = x_2$
 $\dot{x}_2 = -x_1 + 2x_2 - \text{sat}(3x_2)$
- (c) $\dot{x}_1 = x_2$
 $\dot{x}_2 = -2x_1 - 2x_2 - \text{sat}(-x_1 - x_2)$

Which phase portrait belongs to what system?

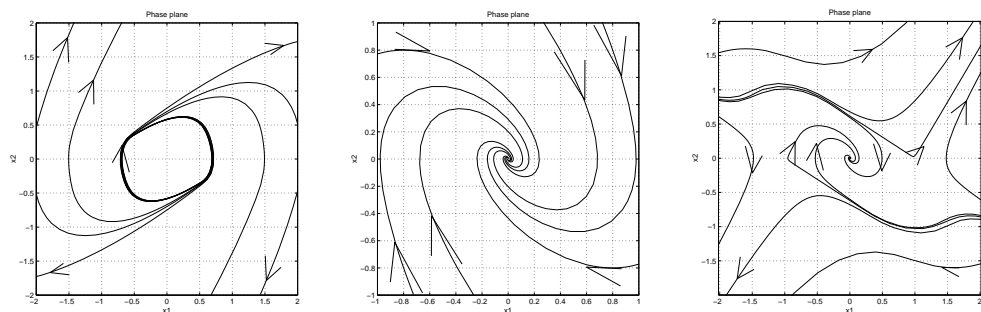

Figure 2.1 Phase portraits for saturated linear systems in Exercise 2.4

□

EXERCISE 2.5[KHALIL, 1996] (H)

The phase portraits of the following two systems are shown in Figures 2.2(a), and 2.2(b), respectively. Mark the arrow heads and discuss the qualitative behaviour of each system.

$$(a) \quad \begin{aligned} \dot{x}_1 &= -x_2 \\ \dot{x}_2 &= x_1 - x_2(1 - x_1^2 + 0.1x_1^4) \end{aligned}$$

$$(b) \quad \begin{aligned} \dot{x}_1 &= x_2 \\ \dot{x}_2 &= x_1 + x_2 - 3 \tan^{-1}(x_1 + x_2) \end{aligned}$$

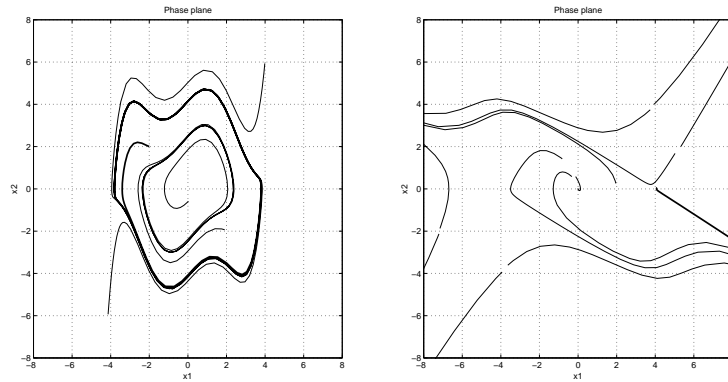

Figure 2.2 Phase portraits for Exercise 2.5(a) to the left, and Exercise 2.5(b) to the right.

□

EXERCISE 2.6

The following system

$$\begin{aligned} \dot{x}_1 &= (u - x_1)(1 + x_2^2) \\ \dot{x}_2 &= (x_1 - 2x_2)(1 + x_1^2) \\ y &= x_2 \end{aligned}$$

is controlled by the output feedback

$$u = -Ky$$

- For all values of the gain K , determine the equilibrium points of the closed loop system.
- Determine the equilibrium character of the origin for all values of the parameter K . Determine in particular for what values the closed loop system is (locally) asymptotically stable.

□

EXERCISE 2.7[ÅSTRÖM, 1968]

As an application of phase plane analysis, consider the model of a synchronous generator derived in Exercise 1.3(b):

$$\begin{aligned} \dot{x}_1 &= x_2 \\ \dot{x}_2 &= \frac{P}{M} - \frac{D}{M}x_2 - \frac{\eta_1}{M}E_q \sin x_1. \end{aligned}$$

The equilibrium points of the system were derived in Exercise 1.3(c). Determine the character of the equilibrium points.

□

EXERCISE 2.8 (H)

Consider the system

$$\begin{aligned} \dot{x}_1 &= x_2 + x_1(1 - x_1^2 - x_2^2) \\ \dot{x}_2 &= -x_1 + x_2(1 - x_1^2 - x_2^2) \end{aligned}$$

- Verify that the trajectory $(x_1, x_2) = (\sin t, \cos t)$ is a solution to the system.
- The trajectory in (a) is periodic and can thus be seen as a limit cycle. Check whether this limit cycle is stable or not.
- Linearize the system around the trajectory(/limit cycle).

□

EXERCISE 2.9

Linearize the ball-on-beam equation

$$\frac{7}{5}\ddot{x} - x\dot{\phi}^2 = g \sin \phi + \frac{2r}{5}\ddot{\phi},$$

around the trajectory

$$(\phi(t), x(t)) = \left(\phi_0, \frac{5g}{7} \sin(\phi_0) \cdot \frac{t^2}{2} \right)$$

□

EXERCISE 2.10

Use a simple trigonometry identity to help find a nominal solution corresponding to $u(t) = \sin(3t)$, $y(0) = 0$, $\dot{y}(0) = 1$ for the equation

$$\ddot{y} + \frac{4}{3}y^3(t) = -\frac{1}{3}u(t).$$

Linearize the equation around this nominal solution.

□

EXERCISE 2.11

The equations for motion of a child on a swing are given by

$$\frac{d}{dt}\left(ml^2\frac{d}{dt}\phi\right) + mgl \sin \phi = 0$$

Here $\phi(t)$ is the angle of the swing, m the mass, and $l(t)$ the distance of the child to the pivot of the swing. The child can excite the swing by changing $l(t)$ by moving its center of mass.

- (a) Draw phase diagrams for two different constant lengths l_1 and l_2 .
- (b) Assume that it is possible to quickly change between the lengths l_1 and l_2 . Show how to jump between the two different systems to increase the amplitude of the swing.

Hint: During constant l the energy in the system is constant. When $l(t)$ changes quickly ϕ will be continuous but $\frac{d}{dt}\phi(t)$ will change in such a way that the angular momentum $ml^2\frac{d}{dt}\phi$ is continuous.

□

Hints

Exercise 2.1 Set $\dot{x}_1 = \dot{x}_2 = 0$ and find necessary conditions on the stationary points by considering the simplest equation. Use this in the other equation.

Exercise 2.5 Note that the sign of x_2 determines the sign of \dot{x}_1 .

Exercise 2.8 Introduce polar coordinates to determine stability of the limit cycle.

$$x_1 = r \cos(\theta)$$

$$x_2 = r \sin(\theta)$$

with $r \geq 0$.

3. Lyapunov Stability

EXERCISE 3.1

Consider the scalar system

$$\dot{x} = ax^3$$

- (a) Show that Lyapunov's linearization method fails to determine stability of the origin.
- (b) Use the Lyapunov function

$$V(x) = x^4$$

to show that the system is globally asymptotically stable for $a < 0$.

- (c) What can you say about the system for $a = 0$?

□

EXERCISE 3.2

Consider the pendulum equation with mass m and length l .

$$\begin{aligned}\dot{x}_1 &= x_2 \\ \dot{x}_2 &= -\frac{g}{l} \sin x_1 - \frac{k}{m} x_2.\end{aligned}$$

- (a) Assume zero friction, (*i.e.* let $k = 0$), and that the mass of the pendulum is concentrated at the tip. Show that the origin is stable by showing that the energy of the pendulum is constant along all system trajectories.
- (b) Show that the pendulum energy alone cannot be used to show asymptotic stability of the origin for the pendulum with non-zero friction, $k > 0$. Then use LaSalle's invariance principle to prove that the origin is asymptotically stable.

□

EXERCISE 3.3

Consider the system

$$\ddot{x} + d\dot{x}^3 + kx = 0,$$

where $d > 0$, $k > 0$. Show that

$$V(x) = \frac{1}{2}(kx^2 + \dot{x}^2)$$

is a Lyapunov function. Is the system locally stable, locally asymptotically stable, and globally asymptotically stable?

□

EXERCISE 3.4

Consider the linear system

$$\dot{x} = Ax = \begin{bmatrix} 0 & -1 \\ 1 & -1 \end{bmatrix} x$$

- (a) Compute the eigenvalues of A and verify that the system is asymptotically stable
- (b) From the lectures, we know that an equivalent characterization of stability can be obtained by considering the Lyapunov equation

$$A^T P + PA = -Q$$

where $Q = Q^T$ is any positive definite matrix. The system is asymptotically stable if and only if the solution P to the Lyapunov equation is positive definite.

- (i) Let

$$P = \begin{bmatrix} p_{11} & p_{12} \\ p_{12} & p_{22} \end{bmatrix}$$

Verify by completing squares that $V(x) = x^T P x$ is a positive definite function if and only if

$$p_{11} > 0, \quad p_{11}p_{22} - p_{12}^2 > 0$$

- (ii) Solve the Lyapunov function with Q as the identity matrix. Is the solution P a positive definite matrix?
- (c) Solve the Lyapunov equation in Matlab.

□

EXERCISE 3.5[SLOTINE AND LI, 1991]

As you know, the system

$$\dot{x}(t) = Ax(t), \quad t \geq 0,$$

is asymptotically stable if all eigenvalues of A have negative real parts. It might be tempted to conjecture that the time-varying system

$$\dot{x}(t) = A(t)x(t), \quad t \geq 0, \tag{3.1}$$

is asymptotically stable if the eigenvalues of $A(t)$ have negative real parts for all $t \geq 0$. This is *not* true.

- (a) Show this by explicitly deriving the solution of

$$\dot{x} = \begin{bmatrix} -1 & e^{2t} \\ 0 & -1 \end{bmatrix} x, \quad t \geq 0.$$

- (b) The system (3.1) is however stable if the eigenvalues of $A(t) + A^T(t)$ have negative real parts for all $t \geq 0$. Prove this by showing that $V = x^T x$ is a Lyapunov function.

□

EXERCISE 3.6[BOYD, 1997]

A student is confronted with the nonlinear differential equation

$$\ddot{x} + \frac{2x}{(1+x^2)^2} = 0$$

and is asked to determine whether or not the equation is stable. The students think “this is an undamped mass-spring system – the spring is nonlinear with a spring constant of $2/(1+x^2)^2$ ”. The student re-writes the system as

$$\begin{aligned}\dot{x}_1 &= x_2 \\ \dot{x}_2 &= \frac{-2x_1}{(1+x_1^2)^2}\end{aligned}$$

and constructs the obvious Lyapunov function

$$V(x) = \int_0^{x_1} \frac{2\zeta}{(1+\zeta^2)^2} d\zeta + \frac{1}{2}x_2^2.$$

The student declares, “ V is positive definite, because everywhere in \mathbb{R}^2 , $V(x) \geq 0$, and $V(x) = 0$ only if $x = 0$.” The student ascertains that $\dot{V} \leq 0$ everywhere in \mathbb{R}^2 and concludes, “the conditions for Lyapunov’s theorem are satisfied, so the system is globally stable about $x = 0$ ”.

- (a) Sadly, there is a mistake in the student’s reasoning. What is the mistake?
- (b) Perhaps the student has merely made a poor choice of Lyapunov function, and the system really is globally stable. Is there some other Lyapunov function that can be used to show global stability? Find such a function, or show that no such function exists.

□

EXERCISE 3.7[SLÖTINE AND LI, 1991] (H)

Consider the system

$$\begin{aligned}\dot{x}_1 &= 4x_1^2x_2 - f_1(x_1)(x_1^2 + 2x_2^2 - 4) \\ \dot{x}_2 &= -2x_1^3 - f_2(x_2)(x_1^2 + 2x_2^2 - 4),\end{aligned}$$

where the continuous functions f_1 and f_2 have the same sign as their arguments, i.e. $x_i f_i(x_i) > 0$ if $x_i \neq 0$, and $f_i(0) = 0$.

- (a) Find all equilibrium points of the system. You may use the fact that due to the property of f_1 , and f_2 stated above, there do not exist any equilibria that satisfy $x_1 \neq 0$ and $x_2 \neq 0$. (*Extra: Prove this fact*)

(b) Show that

$$E = \{x \mid x_1^2 + 2x_2^2 = 4\}$$

is an invariant set.

(c) Show that almost all trajectories of the system tend towards the invariant set E .

(d) Is E a limit cycle?

Extra: Simulate the system.

(Remark. Compare with Example 3.13 in the book by Slotine and Li.)

□

EXERCISE 3.8

Consider the system

$$\begin{aligned}\dot{x}_1 &= x_2 \\ \dot{x}_2 &= -2x_1 - 2x_2 - 4x_1^3.\end{aligned}$$

Use the function

$$V(x) = 4x_1^2 + 2x_2^2 + 4x_1^4$$

to show that

- (a) the system is globally stable around the origin.
- (b) the origin is globally asymptotically stable.

□

EXERCISE 3.9

Consider the system

$$\dot{y} = \text{sat}(-3y - 2y).$$

- (a) Show that $y(t) \rightarrow 0$ as $t \rightarrow \infty$.
- (b) For PhD students. Is it possible to prove global asymptotic stability using a Lyapunov function $V(x)$ that satisfies

$$\alpha\|x\|_2^2 \leq V(x) \leq \beta\|x\|_2^2, \quad \dot{V}(x) \leq -\gamma\|x\|_2^2$$

for some positive scalars α and β ?

- (c) For PhD students. Consider the system

$$\ddot{x} = u$$

and show that all feedback laws $u = k_1x + k_2\dot{x}$ that give an asymptotically stable system, also give an asymptotically stable system when the actuator saturates, *i.e.*, when

$$\ddot{x} = \text{sat}(u).$$

- (d) For PhD students. Does the results in (c) hold for the triple integrator

$$\frac{d^3x}{dt^3} = \text{sat}(u)? \tag{3.2}$$

□

EXERCISE 3.10[BOYD, 1997]

The set $\{z \in \mathbb{R}^n | \dot{V}(z) = 0\}$ arising in invariance theorems (such as LaSalle's theorem) is usually a 'thin' hypersurface, but it need not be. Carefully prove global asymptotic stability of

$$\begin{aligned}\dot{x}_1 &= x_2 \\ \dot{x}_2 &= -x_1 - \max(0, x_1) \cdot \max(0, x_2)\end{aligned}$$

using the Lyapunov function $V(x) = x^T x$.

□

EXERCISE 3.11

Consider the nonlinear system

$$\begin{aligned}\dot{x}_1 &= -x_1 + x_2 \\ \dot{x}_2 &= -x_1 - x_2 + g(x)\end{aligned}$$

- (a) Show that $V(x) = 0.5x^T x$ is a Lyapunov function for the system when $g(x) = 0$.
- (b) Use this Lyapunov function to show that the system is globally asymptotically stable for all $g(x)$ that satisfy

$$\begin{aligned}g(x) &= g(x_2) \\ \text{sign}(g(x_2)) &= -\text{sign}(x_2)\end{aligned}$$

- (c) Let $g(x) = x_2^3$. This term does not satisfy the conditions in (a). However, we can apply Lyapunov's linearization method to show that the origin is still locally asymptotically stable.

For large initial values, on the other hand, simulations reveal that the system is unstable. It would therefore be interesting to find the set of "safe" initial values, such that all trajectories that start in this set tend to the origin. This set is called the *region of attraction* of the origin. We will now illustrate how quadratic Lyapunov functions can be used to estimate the region of attraction.

- (i) Show that $\dot{V}(x) < 0$ for $|x_2| < 1$. This means that $V(x)$ decreases for all solutions that are confined in the strip $|x_2(t)| < 1$ for all t .
- (ii) Recall that level sets for the Lyapunov function are invariant. Thus, solutions that start inside a proper level set remain there for all future times. Conclude that the region of attraction can be estimated as the largest level set

$$\Omega = \{x : V(x) \leq \gamma\}$$

for which $|x_2| < 1$. Compute the maximum value of γ .

□

EXERCISE 3.12[KHALIL, 1996]

Consider the second order system

$$\begin{aligned}\dot{x}_1 &= -x_2 \\ \dot{x}_2 &= x_1 + (x_1^2 - 1)x_2.\end{aligned}$$

(This is the Van der Pol oscillator ran backwards in time.)

- Use linearization and a quadratic Lyapunov function to show that the origin is asymptotically stable.
- Estimate the region of attraction for the nonlinear system using the quadratic Lyapunov derived in (a). (*Hint.* Transform the system into polar coordinates, $x_1 = r \cos(\theta)$, $x_2 = r \sin(\theta)$ and find the largest radius r so that Lyapunov function is decreasing for all x in the ball $B_r = \{x \in \mathbb{R}^2 : \|x\|_2 \leq r\}$.)
- The procedure used in (b) tends to give quite conservative estimates of the region of attraction. Can you think of some method to get better estimates of the region of attraction, or to enlarge the estimate derived above?

□

EXERCISE 3.13[KHALIL, 1996]

Consider the system

$$\begin{aligned}\dot{x}_1 &= x_2 \\ \dot{x}_2 &= x_1 - \text{sat}(2x_1 + x_2).\end{aligned}$$

- Show that the origin is asymptotically stable.
- Show that all trajectories starting in the first quadrant to the right of the curve

$$x_1 x_2 = c$$

for sufficiently large c , cannot reach the origin. (*Hint:* Consider $V(x) = x_1 x_2$; calculate $\dot{V}(x)$ and show that on the curve $V(x) = c$, the derivative $\dot{V}(x) > 0$ when c is sufficiently large.)

- Show that the origin is not globally asymptotically stable.

□

EXERCISE 3.14[BOYD, 1997]

So far, we have only considered stability of autonomous systems, *i.e.* systems without an external input. If we are faced with an open-loop unstable system with an input that we can manipulate, a key question is whether it is possible to find a control law that gives a stable closed-loop system. We can use Lyapunov theory to give some answers to this question.

We say that the single-input system

$$\dot{x} = f(x, u), \quad x \in \mathbb{R}^n, u \in \mathbb{R}$$

is *stabilizable* if there is a state feedback $u = k(x)$ that results in a globally asymptotically stable closed-loop system.

- (a) Consider the special case when

$$\dot{x} = f(x, u) = \phi(x) + \psi(x)u,$$

and show that the system is stabilizable if there is positive definite function V , such that the function

$$\left(\frac{\partial V}{\partial x}\right)\phi(x) - \left(\left(\frac{\partial V}{\partial x}\right)\psi(x)\right)^2$$

is negative definite. (*Hint.* Try to find a feedback in terms of $V(x)$, $\phi(x)$, and $\psi(x)$ that makes $V(x)$ a Lyapunov function for the closed loop system.)

- (b) For PhD students. Show that the linear system
- $\dot{x} = Ax + bu$
- is stabilizable if and only if there is a
- $P = P^T$
- such that

$$AP + PA^T - bb^T < 0.$$

(*Hint.* Some LQR theory may come handy when proving necessity. In particular, if the system is stabilizable, what can you say about the feedback law $u = -kx$ that you obtain from the LQR cost $\int_0^\infty x^T x + u^T u dt$?)

□

EXERCISE 3.15

It can sometimes be convenient to re-write nonlinearities in a way that is more easy to manipulate. Consider the single input, open loop stable, linear system under saturated feedback

$$\begin{aligned}\dot{x} &= Ax + B\text{sat}(u) \\ u &= -Kx.\end{aligned}$$

- (a) Show that this system can be re-written in the form

$$\dot{x} = Ax + \mu(x)BKx,$$

where $0 < \mu(x) \leq 1$.

- (b) Assume
- $P > 0$
- is such that

$$x^T(A^T P + PA)x \leq 0, \forall x$$

. Show that all feedback gains K that satisfies

$$x^T((A - BK)^T P + P(A - BK))x \leq 0, \forall x$$

guarantees the closed loop system in (a) to be stable. (The nice thing about this formulation is that it is possible to construct efficient numerical methods for simultaneously finding both feedback gains K and Lyapunov matrix P).

(c) For PhD students. Consider the nonlinear system

$$\begin{aligned}\dot{x} &= Ax + f(x) + B\text{sat}(u) \\ u &= -Kx.\end{aligned}$$

Assume that the perturbation term satisfies $f(0) = 0$ and that $f(x)$ is globally Lipschitz with Lipschitz constant k_f , i.e.,

$$|f(x) - f(y)| \leq k_f |x - y|, \quad k_f > 0.$$

Let Q be given by the Lyapunov equation $A^T P + PA = -Q$, with $P > 0$. Show that if the Lipschitz constant satisfies

$$k_f < \frac{\lambda_{\min}(Q)}{2\lambda_{\max}(P)},$$

then the system is globally stabilizable by linear feedback. Also, suggest a feedback law that stabilizes the system. □

EXERCISE 3.16

In general, it is non-trivial to find a Lyapunov function for a given nonlinear system. Several different methods have been derived for specific classes of systems. In this exercise, we will investigate the following method, known as Krasovskii's method.

Consider systems on the form

$$\dot{x} = f(x)$$

with $f(0) = 0$. Assume that $f(x)$ is continuously differentiable and that its Jacobian, $\partial f / \partial x$, satisfies

$$P \frac{\partial f}{\partial x}(x) + \left(\frac{\partial f}{\partial x}(x) \right)^T P \leq -I$$

for all $x \in \mathbb{R}^n$, and some matrix $P = P^T > 0$. Then, the origin is globally asymptotically stable with $V(x) = f^T(x) P f(x)$ as Lyapunov function.

Prove the validity of the method in the following steps.

(a) Verify that $f(x)$ can be written as

$$f(x) = \int_0^1 \frac{\partial f}{\partial x}(\sigma x) \cdot x d\sigma.$$

and use this representation to show that the assumptions imply

$$x^T P f(x) + f^T(x) P x \leq -x^T x, \quad \forall x \in \mathbb{R}^n$$

(b) Show that $V(x) = f^T(x) P f(x)$ is positive definite for all $x \in \mathbb{R}^n$.

(c) Show that $V(x)$ is radially unbounded.

- (d) Using $V(x)$ as a Lyapunov function candidate, show that the origin is globally asymptotically stable.

□

EXERCISE 3.17

Use Krasovskii's method to justify Lyapunov's linearization method.

□

EXERCISE 3.18[ÅSTRÖM, 1968]

Consider the servo system in Figure 3.18. Introduce state variables x_1 and

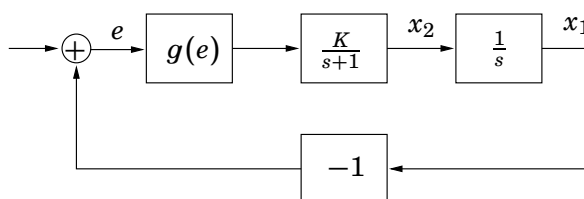

Figure 3.1 The pendulum in Exercise 1.1

x_2 as indicated in the figure. Assume that the reference value is zero. The system equations can then be written as

$$\begin{aligned}\dot{x}_1 &= x_2 \\ \dot{x}_2 &= -x_2 + Kg(e) = -x_2 + Kg(-x_1).\end{aligned}$$

Let the nonlinearity be on the form $g(e) = e^3$ and investigate stability of the closed loop system. (*Hint:* Use $V(x) = f(x)^T P f(x)$ (Krasovskii's method) with suitable P .)

□

Hints*Excercise 3.7*

b) Show that if $x(T) \in E$ then $x_1^2(t) + 2x_2^2(t) = 4$ for all $t \geq T$.

c) Define a function $V(x)$ such that $V = 0$ on E and $V(x) > 0$ if $x \notin E$, and start by showing that $\dot{V} \leq 0$.

4. Input-Output Stability

EXERCISE 4.1

The norms used in the definitions of stability need not be the usual Euclidian norm. If the state-space is of finite dimension n (*i.e.*, the state vector has n components), stability and its type are independent of the choice of norm (all norms are “equivalent”), although a particular choice of norm may make analysis easier. For $n = 2$, draw the unit balls corresponding to the following norms.

- (a) $\|x\|^2 = x_1^2 + x_2^2$ (Euclidian norm)
- (b) $\|x\|^2 = x_1^2 + 5x_2^2$
- (c) $\|x\| = |x_1| + |x_2|$
- (d) $\|x\| = \sup(|x_1|, |x_2|)$

Recall that a “ball” $B(x_0, R)$, of center x_0 and radius R , is the set of x such that $\|x - x_0\| \leq R$, and that the unit ball is $B(0, 1)$.

□

EXERCISE 4.2

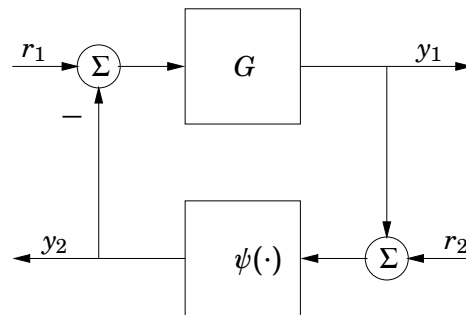

Figure 4.1 Feedback connection form

Consider an asymptotically stable linear time invariant system G interconnected with a static nonlinearity ψ in the standard form (see Figure 4.1). Compare the Nyquist, Circle, Small Gain, and Passivity Criterion with respect to the following issues.

- (a) What are the restrictions that must be imposed on ψ in order to apply the different stability criteria?
- (b) What restrictions must be imposed on the Nyquist curve of the linear system in order to apply the stability criteria above?
- (c) Which of the stability theorems above can handle dynamic nonlinearities?

□

EXERCISE 4.3

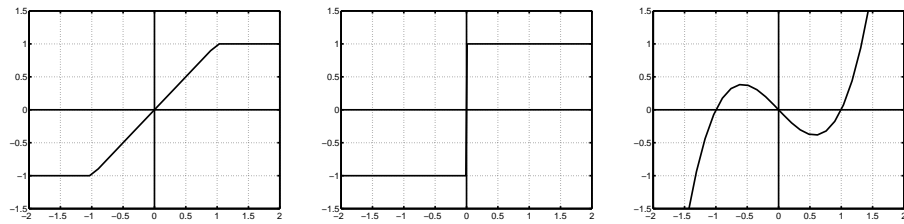

Figure 4.2 Static nonlinearities in Exercise 4.3.

Consider the static nonlinearities shown in Figure 4.2. For each nonlinearity,

- (a) determine the minimal sector $[\alpha, \beta]$,
- (b) determine the gain of the nonlinearity,
- (c) determine if the nonlinearity is passive.

□

EXERCISE 4.4[KHALIL, 1996]

The Nyquist curve of

$$G(s) = \frac{4}{(s + 1)(s/2 + 1)(s/3 + 1)}$$

is shown in Figure 4.3 together with a circle with center in 1.5 and with radius 2.85.

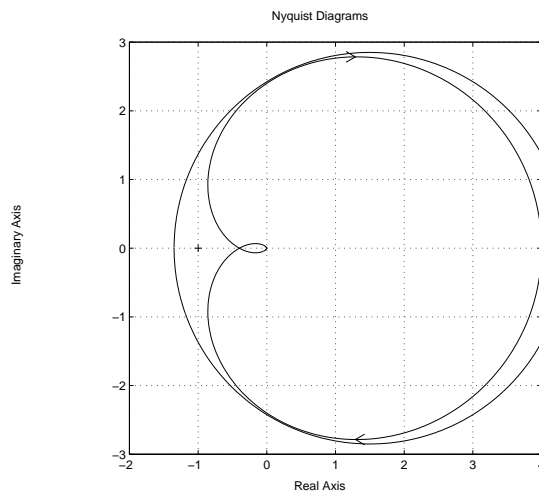

Figure 4.3 The Nyquist-curve in Exercise 4.4

- (a) Determine the maximal stability sector of the form $(-\alpha, \alpha)$.
- (b) Use the circle in the figure to determine another stability sector.
- (c) What is the maximal stability sector of the form $(0, \beta)$?

□

EXERCISE 4.5[KHALIL, 1996]

The Nyquist curve of

$$G(s) = \frac{4}{(s-1)(s/3+1)(s/5+1)}$$

is shown in Figure 4.4 . Determine a possible stability sector (α, β) .

Figure 4.4 The Nyquist-curve in Exercise 4.5

□

EXERCISE 4.6[KHALIL, 1996]

Using the circle criterion, for each of the scalar transfer functions below, find a sector (α, β) for which the system is BIBO stable. Their Nyquist diagrams are available in figure 4.5.

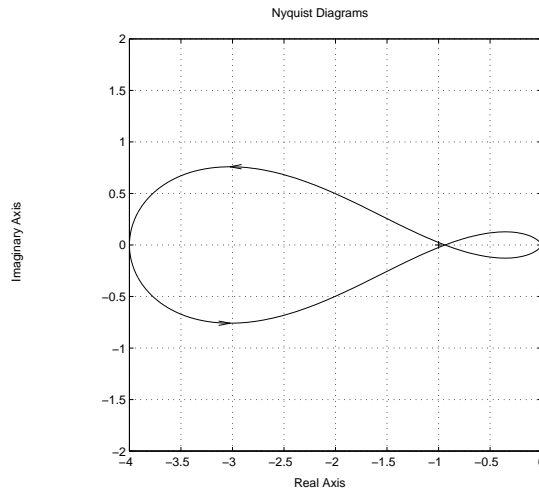
(a)

$$G(s) = \frac{1}{(s+1)(s+2)}$$

(b)

$$G(s) = \frac{s}{s^2 - s + 1}$$

Hint for (b): Here, $G(s)$ is not stable, but could be stabilized by linear feedback which is then subtracted from the nonlinear function. See also lecture slides about the circle criterion for an unstable system $G(s)$.

□

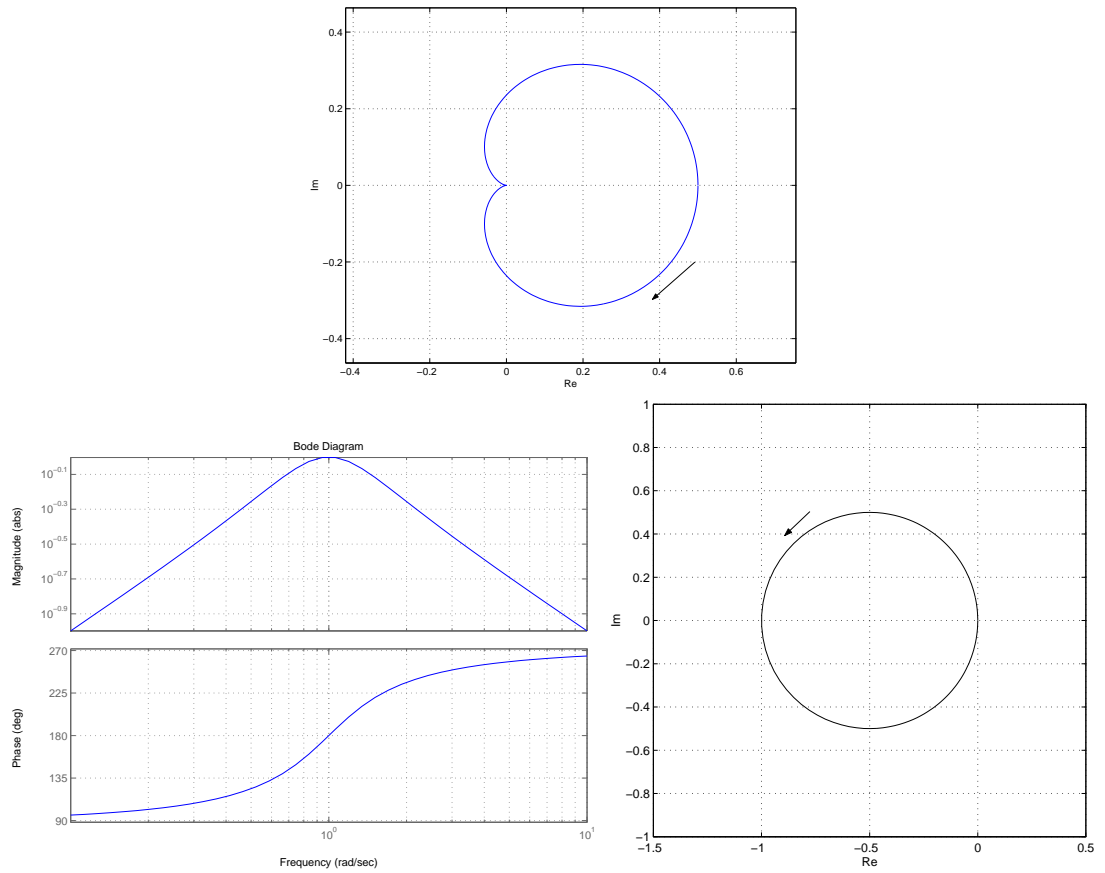

Figure 4.5 Nyquist curves for the system in Exercise 4.6a (above) and Bode and Nyquist curve for the system in Exercise 4.6b (below)

EXERCISE 4.7 (H)

Consider the linear time-varying system

$$\dot{x}(t) = (A + B\delta(t)C)x,$$

- (a) Show that the system can be written as a feedback connection of a linear time invariant system with transfer function

$$G(s) = C(sI - A)^{-1}B$$

and a time-varying multiplication operator ψ defined by δ (i.e. $\psi(y) = \delta y$).

- (b) Let A be Hurwitz (i.e. asymptotically stable), let $G(s)$ have one input and one output, and let $\sup_{t \geq 0} |\delta(t)| \leq 1$. Show that if

$$\sup_{\omega \in \mathbb{R}} |G(i\omega)| < 1$$

then the system is BIBO stable.

- (c) Figure 4.6 shows the Nyquist curves for different transfer functions $G(s)$. Which transfer functions will give a BIBO stable closed loop according to the criteria in (b)?

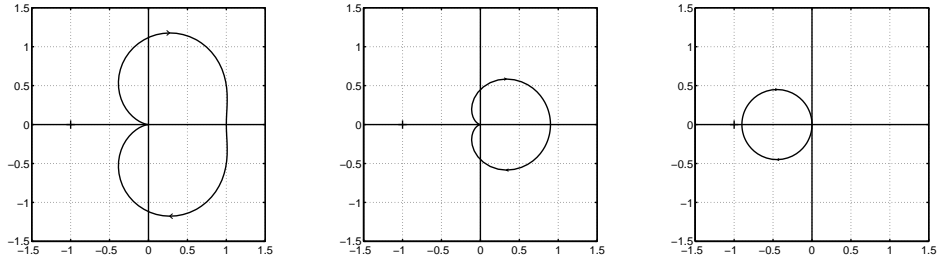

Figure 4.6 Nyquist curves for transfer function $G(s)$ in Exercise 4.7.

- (d) For PhD students. Let $G(s)$ be a transfer function matrix with m inputs and n outputs. Show that if A is Hurwitz, $\|\Delta(t)\| \leq 1 \forall t$, and $\sup_{\omega \in \mathbb{R}} \sigma_{max}[C(j\omega I - A)^{-1}B] < 1$, then the system is BIBO stable.

□

EXERCISE 4.8

The singular values of a matrix A are denoted $\sigma_i(A)$.

- (a) Use Matlab to compute $\sigma(A)$ for

$$A = \begin{bmatrix} 1 & 10 \\ 0 & 1 \end{bmatrix}.$$

- (b) The maximal singular value is defined by

$$\sigma_1(A) = \sup_x \frac{|Ax|}{|x|}.$$

Show that $\sigma_1(AB) \leq \sigma_1(A)\sigma_1(B)$.

□

EXERCISE 4.9

In the previous chapter, we have seen how we can use Lyapunov functions to prove stability of systems. In this exercise, we shall see how another type of auxiliary functions, called *storage functions*, can be used to assess passivity of a system.

Consider the nonlinear system

$$\begin{aligned} \dot{x} &= f(x, u) \\ y &= g(x, u) \end{aligned} \tag{4.1}$$

with zero initial conditions, $x(0) = 0$. Show that if we can find a *storage function* $V(x, u)$ with the following properties

- $V(x, u)$ is continuously differentiable.
- $V(0) = 0$ and $V(x, u) \geq 0$ for $x \neq 0$.
- $u^T y \geq \dot{V}(x, u)$.

then, the system (4.1) is passive.

□

EXERCISE 4.10Let P be the solution to

$$A^T P + PA = -I,$$

where A is an asymptotically stable matrix. Show that $G(s) = B^T P (sI - A)^{-1} B$ is passive. (*Hint.* Use the function $V(x) = x^T P x$.)

□

EXERCISE 4.11[BOYD, 1997]

Consider the dynamic controller

$$\dot{y} = -2y + \text{sat}(y) + u, \quad y(0) = y_0.$$

- (a) Show that the system is passive.
- (b) Is the system strictly passive?
- (c) A DC motor is characterized by

$$\begin{aligned} \dot{\theta} &= \omega \\ \dot{\omega} &= -\omega + \eta, \end{aligned}$$

where θ is the shaft angle and η is the input voltage. The dynamic controller

$$\begin{aligned} \dot{z} &= 2(\theta - z) - \text{sat}(\theta - z) \\ \eta &= z - 2\theta \end{aligned}$$

is used to control the shaft position. Use any method you like to prove that $\theta(t)$ and $\omega(t)$ converge to zero as $t \rightarrow \infty$.

□

EXERCISE 4.12

- (a) Let $u_c(t)$ be an arbitrary function of time and let $H(\cdot)$ be a passive system. Show that

$$y(t) = u_c(t) \cdot H(u_c(t)u(t))$$

is passive from u to y .

- (b) Show that the following adaptive system is stable

$$\begin{aligned} e(t) &= G(s) (\theta(t) - \theta^0) u_c(t) \\ \dot{\theta}(t) &= -\gamma u_c(t) e(t), \end{aligned}$$

if $\gamma > 0$ and $G(s)$ is strictly passive.

EXERCISE 4.13PHDLet f be a static nonlinearity in the sector $(0, \infty)$.

- (a) Show that the system $\dot{x} = \gamma x + e$, $y = f(x)$ is passive from e to y if $\gamma \geq 0$.
- (b) Show that if the Popov criterion

$$\operatorname{Re} (1 + \gamma i\omega)G(i\omega) > 0, \quad \forall \omega,$$

is satisfied, with $\gamma \geq 0$, then the closed loop system in Figure 4.7 is absolutely stable.

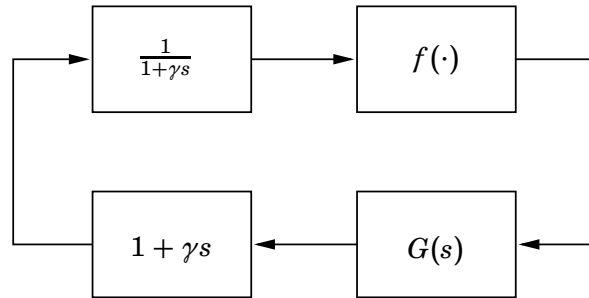

Figure 4.7 Proof of the Popov criterion in Exercise 4.13.

- (c) How does the Popov criterion change if f is in the sector (α, β) instead?
- (d) Figure 4.8 shows the Nyquist curve and the Popov curve $(\operatorname{Re} G(i\omega), \omega \operatorname{Im} G(i\omega))$ for the system

$$G(s) = \frac{s + 1}{s(s + 0.1)(s^2 + 0.5s + 9)}.$$

Determine a stability sector $(0, \beta)$ using the line in the figure.

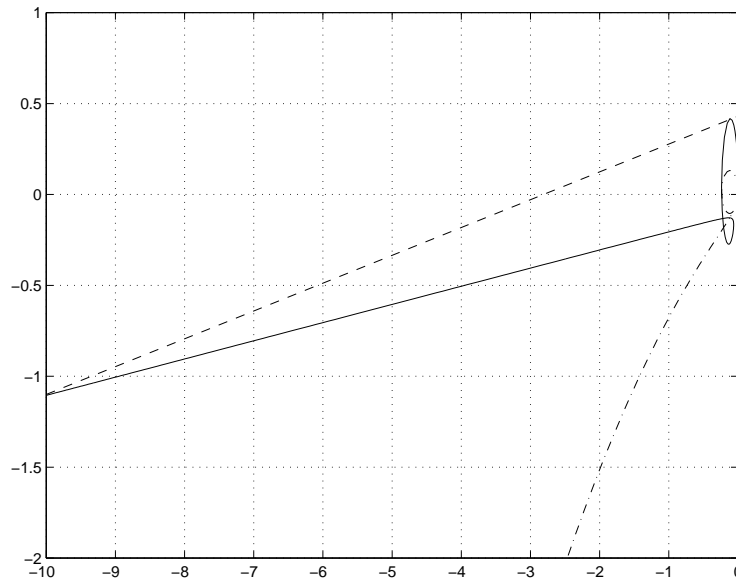

Figure 4.8 Nyquist (dash-dot) and Popov curve (solid) for the system in Exercise 4.13d. The Popov curve is to the right of the dashed line for all ω .

□

Hints

Exercise 4.7

b) Use the definition of L_2 -norm in the lecture slides to show that $\gamma(\psi) \leq 1$ by showing

$$\|\psi(y)\|_2 \leq \|\delta\|_\infty \|y\|_2 \leq \|y\|_2$$

and then apply the appropriate theorem.

5. Describing Function Analysis, Limit Cycles

EXERCISE 5.1 (H)

Match each of the odd, static nonlinearities in Figure 5.1 with one of the describing functions in Figure 5.2.

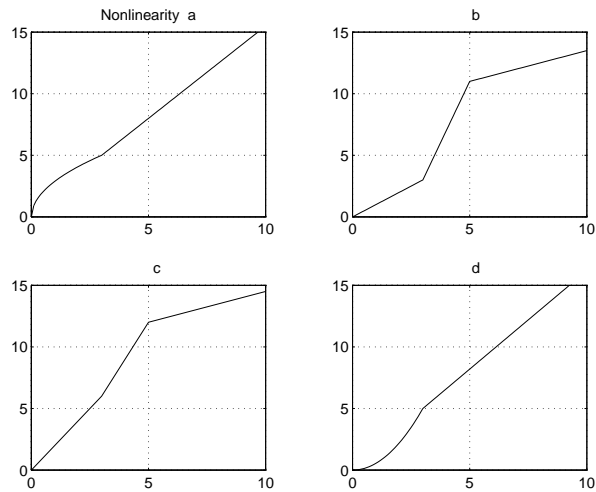

Figure 5.1 Nonlinearities in Exercise 5.1

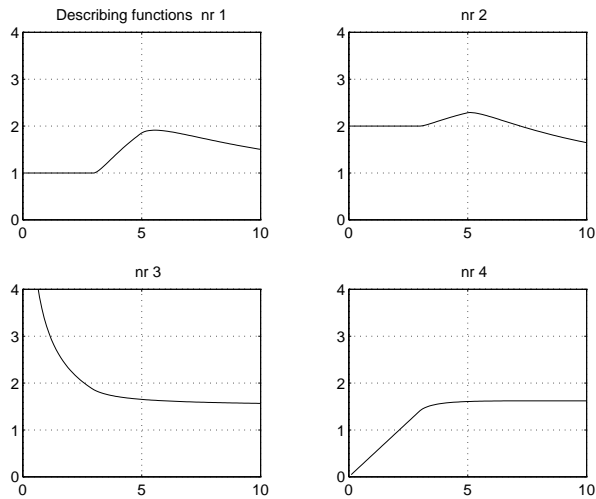

Figure 5.2 Describing functions $N(A)$ as a function of A for the odd, static nonlinearities in Exercise 5.1.

□

EXERCISE 5.2

Compute the describing functions for

- (a) the saturation,
- (b) the deadzone, and
- (c) the piece-wise linear function

in Figure 5.3. (*Hint:* Use (a) in (b) and (c).)

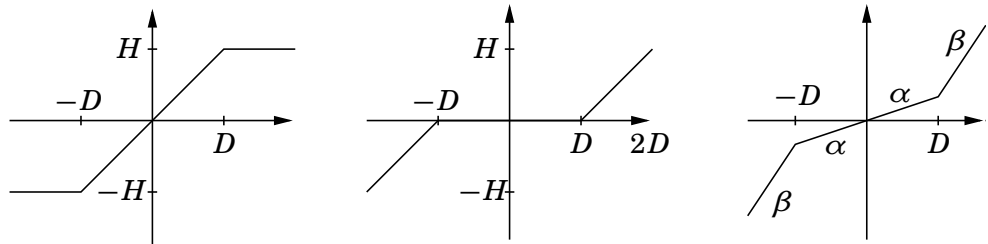

Figure 5.3 The static nonlinearities in Exercise 5.2

□

EXERCISE 5.3

Show that the describing function for a relay with hysteresis in Figure 5.4 satisfies

$$-\frac{1}{N(A)} = -\frac{\pi A}{4H} \left(\left(1 - \left(\frac{D}{A} \right)^2 \right)^{1/2} + i \frac{D}{A} \right).$$

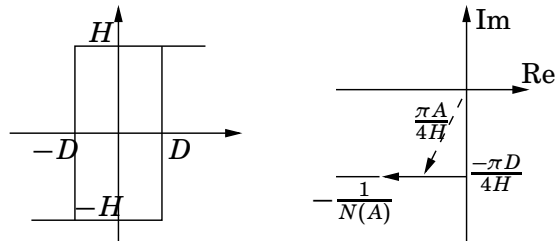

Figure 5.4 The relay with hysteresis in Exercise 5.3.

□

EXERCISE 5.4

If the describing function for the static nonlinearity $f(x)$ is $Y_N(C)$, then show that the describing function for $Df(x/D)$ equals $Y_N(C/D)$, where D is a constant.

□

EXERCISE 5.5

Show that all odd, static nonlinearities f such that

$$\frac{df(x)}{dx} > 0, \quad \frac{d^2f(x)}{dx^2} > 0,$$

for $x > 0$, have a real describing function $\Psi(\cdot)$ that satisfies the inequalities

$$\Psi(a) < \frac{f(a)}{a}, \quad a > 0.$$

□

EXERCISE 5.6[ÅSTRÖM, 1968]

Compute the describing function for a static nonlinearity of the form

$$f(x) = k_1x + k_2x^2 + k_3x^3.$$

How does the term k_2x^2 influence the analysis?

□

EXERCISE 5.7[SLÖTINE AND LI, 1991] (H)

Consider the system in Figure 5.5, which is typical of the dynamics of electronic oscillators used in laboratories. Let

$$G(s) = \frac{-5s}{s^2 + s + 25}$$

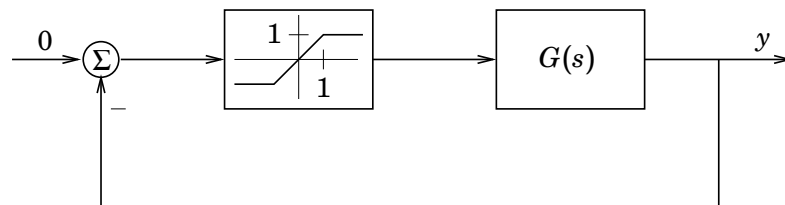

Figure 5.5 Electronic oscillator.

- (a) Assess intuitively the possibility of a limit cycle, by assuming that the system is started at some small initial state, and notice that the system can neither stay small (because of instability) nor at saturation values (by applying the final value theorem of linear control).
- (b) Use the describing function method to predict whether the system exhibits a limit cycle. In such cases, determine the frequency and amplitude of the limit cycle. The describing function of a saturation is plotted in Figure 5.6.
- (c) Use the extended Nyquist criterion to assess whether the limit cycle is stable or unstable.

□

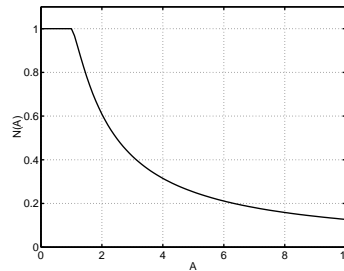

Figure 5.6 Normalized describing function.

EXERCISE 5.8

Consider a servo motor with transfer function

$$G_0(s) = \frac{4}{s(s + 1)(s + 2)}$$

controlled by a relay with a dead-zone a as shown in Figure 5.7.

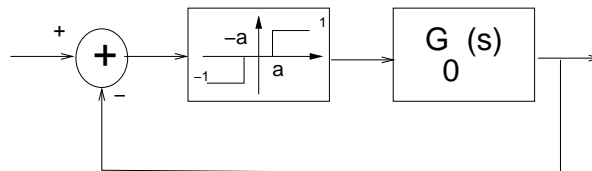

Figure 5.7 Position servo in Exercise 5.8.

- (a) Show that the describing function for the relay with dead-zone a is given by

$$N(A) = \begin{cases} 0 & A < a \\ \frac{4}{\pi A} \sqrt{1 - \frac{a^2}{A^2}} & A \geq a \end{cases}$$

- (b) How should the parameter a be chosen so that the describing function method predicts that sustained oscillations are avoided in the closed loop system?

□

EXERCISE 5.9

The Ziegler-Nichols frequency response method suggest PID parameters based on a system's ultimate gain K_u and ultimate period T_u according to the following table. The method provides a convenient method for tuning PID controllers, since K_u and T_u can be estimated through simple experiments. Once K_u and T_u have been determined, the controller parameters are directly given by the formulas above.

- (a) Show that the parameters K_u and T_u can be determined from the sustained oscillations that may occur in the process under relay feedback. Use the describing function method to give a formula for computing K_u

Parameter	Value
K	$0.6K_u$
T_i	$0.5T_u$
T_d	$0.125T_u$

Table 5.1 Tuning rules for Ziegler-Nichol's method.

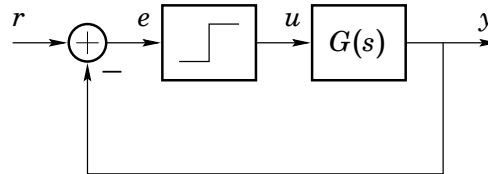

Figure 5.8 An auto-tuning experiment: linear system under relay feedback.

and T_u based on oscillation data. (amplitude A and angular frequency ω of the oscillation). Let the relay amplitude be D .

Recall that the ultimate gain and ultimate period are defined in the following way. Let $G(s)$ be the systems transfer function, and ω_u be the frequency where the system transfer function has a phase lag of -180 degrees. Then we have

$$T_u = 2\pi/\omega_u$$

$$K_u = 1/|G(i\omega_u)|$$

- (b) What parameters would the relay method give for the process

$$G(s) = \frac{50}{s(s+1)(s+10)}$$

which is simulated in Figure 5.9 with $D = 1$? Compare what you obtain from analytical computations ($K_u = 2.20$, $T_u = 1.99$)

□

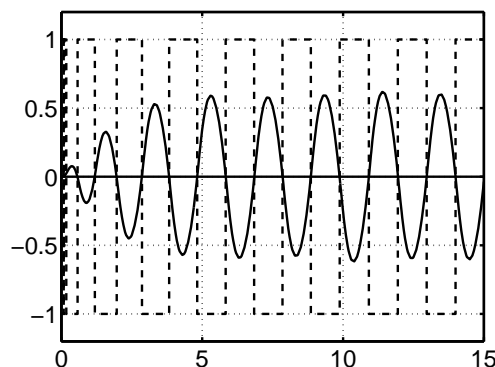

Figure 5.9 Input and output of system under relay feedback.

EXERCISE 5.10[SLOTINE AND LI, 1991]

In many cases, it is desirable to limit the high frequency content in a signal. Usually, such filtering is performed using a linear low-pass filter. Unfortunately, this type of filtering introduces phase lags. If the limiter is positioned within a feedback loop, this phase lag can be harmful for system stability.

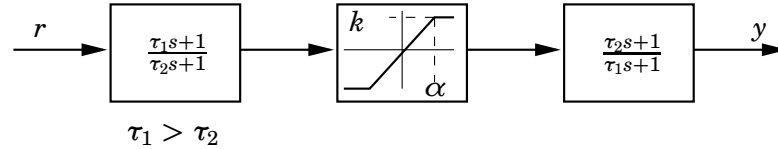

Figure 5.10 The nonlinear lowpass filter suggested in Exercise 5.10.

Figure 5.10 shows an alternative way of limiting the high frequency content of a signal. The system is composed of a high pass filter, a saturation, and a lowpass filter. Show that the system can be viewed as a nonlinear lowpass filter that attenuates high-frequency inputs without introducing a phase lag.

□

EXERCISE 5.11[KHALIL, 1996]

Consider the second order system

$$\begin{aligned} \dot{x}_1 &= x_1 - x_2 - x_1(x_1^2 + x_2^2) \\ \dot{x}_2 &= x_1 + x_2 - x_2(x_1^2 + x_2^2) \end{aligned}$$

- (a) Show that the unit circle is a periodic orbit.
- (b) Use a Poincaré map to show that the periodic orbit derived in (a) is asymptotically stable.
- (b) Use the Lyapunov function candidate $V = r^2 - 1$ (together with La Salle's Theorem) and show that the limit cycle derived in (a) is globally asymptotically stable.

□

EXERCISE 5.12PHD

Show that the system

$$G(s) = \frac{1}{s(s+1)^2}$$

with relay feedback has a locally stable limit cycle.

□

EXERCISE 5.13PHD

Consider a linear system with relay feedback:

$$\begin{aligned}\dot{x} &= Ax + Bu, \\ y &= Cx, \\ u &= -\text{sgn } y,\end{aligned}$$

where A is assumed to be non-singular. In this exercise we will study limit cycles for this system. The Jacobian of the Poincaré map will be derived. It gives a condition for local stability of the limit cycles.

- (a) Draw a figure that illustrates a limit cycle for the system if the linear dynamics is of third order.
- (b) Consider an initial point $x(0) = z$ that satisfies $Cz = 0$, that is, z lies in the switch plane. Show that the Poincaré map from z to next switch plane intersection is

$$g(z) = e^{Ah(z)}z - (e^{Ah(z)} - I)A^{-1}B, \quad (5.1)$$

where $h(z)$ is the time it takes from z to next switch plane intersection.

- (c) A limit cycle corresponds to a fix point z^* of $-g$, that is, a point such that $z^* = -g(z^*)$. Let $h(z)$ in (5.1) be equal to h and solve the equation $z^* = -g(z^*)$. (The solution is a function of h .)
- (d) Consider a perturbed initial point $z + \delta z$ and a perturbed switch time $h + \delta h$. Derive a first-order Taylor expansion of g and show that

$$g(z + \delta z) = -z + e^{Ah}\delta z - (Az + B)\delta h + O(\delta^2), \quad (5.2)$$

where $O(\delta^2)$ represents second-order and higher-order terms in δz and δh .

- (e) Let the perturbations δz and δh be such that both the perturbed initial point and the Poincaré mapping of it lie in the switch plane. This is equivalent to that $C\delta z = 0$ and $Cg(z + \delta z) = 0$. Show by using (5.2) and $Cg(z + \delta z) = 0$ that asymptotically (when $\delta z \rightarrow 0$)

$$\delta h = \frac{Ce^{Ah}}{C(Az + B)}\delta z.$$

- (f) Use (d) and (e) to show that

$$g(z + \delta z) = -z + \left(I - \frac{(Az + B)C}{C(Az + B)}\right)e^{Ah}\delta z.$$

We have now shown that the Jacobian of the Poincaré map for a linear system with relay feedback is equal to the matrix

$$\frac{(Az + B)C}{C(Az + B)}e^{Ah}.$$

The limit cycle is locally stable if and only if this matrix has all eigenvalues in the unit disc.

(g) [Matlab exercise] Choose a state-space representation so that

$$C(sI - A)^{-1}B = \frac{1}{(s + 1)^3}.$$

In c you derived the solution $z^* = z^*(h)$. Plot the scalar function $Cz^*(h)$ as a function of h . The zero crossing at $h > 0$ indicate a possible stable limit cycle. What is h^* ?

Let $z = z^*(h^*)$ and $h = h^*$. Derive the eigenvalues of

$$\frac{(Az + B)C}{C(Az + B)}e^{Ah}.$$

□

□

Hints

Exercise 5.1

Use the interpretation of the describing function $N(A)$ as “equivalent gain” for sinusoidal inputs with amplitude A .

Exercise 5.7

b and c) Given $G(s) = \frac{Q(s)}{P(s)}$, you can split the frequency response into a real part and imaginary part as:

$$G(i\omega) = \frac{Q(i\omega)}{P(i\omega)} = \frac{\operatorname{Re}\{Q(i\omega)P(-i\omega)\}}{|P(i\omega)|^2} + \frac{\operatorname{Im}\{Q(i\omega)P(-i\omega)\}}{|P(i\omega)|^2}$$

This is useful for plotting the Nyquist curve.

6. Anti-windup, Friction, Backlash, Quantization

EXERCISE 6.1

Figure 6.1 (a) shows a controller in polynomial form, $R(s)u = T(s)u_c - S(s)y$, where u is the control signal, y the measurement variable, and u_c the reference signal. Figure (b) shows an antiwindup scheme for the same controller. Assume that the anti-windup controller is controlling a process given by the transfer function $A(s)y = B(s)u$. Also, put $u_c = 0$.

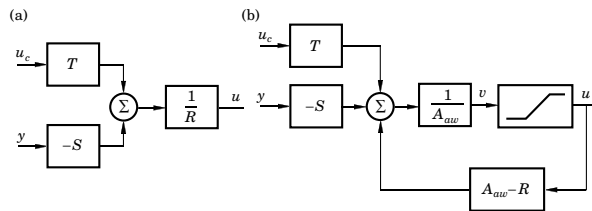

Figure 6.1 Anti-windup scheme considered in Problem 6.1

Make a block transformation to write the system in standard feedback form with lower block $P = \frac{AR+BS}{AA_{aw}} - 1$. Use the circle criterion to conclude that the system is globally asymptotically stable if A is stable and the following condition holds:

$$\operatorname{Re} \left(\frac{AR + BS}{AA_{aw}}(i\omega) \right) \geq \epsilon > 0, \quad \forall \omega.$$

□

EXERCISE 6.2

The following model for friction is described in a PhD thesis by Henrik Olsson:

$$\begin{aligned} \frac{dz}{dt} &= v - \frac{|v|}{g(v)}z \\ F &= \sigma_0 z + \sigma_1(v) \frac{dz}{dt} + F_v v, \end{aligned}$$

where σ_0, F_v are positive constants and $g(v)$ and $\sigma_1(v)$ are positive functions of velocity.

- For non-zero constant velocity, determine the stationary value of z and its stability.
- What friction force does the model give in stationarity for non-zero constant velocity?
- Prove that if $0 < g(v) \leq a$ and $|z(0)| \leq a$ then

$$|z(t)| \leq a, \quad t \geq 0$$

(Hint: Use the function $V(z) = z^2$)

- (d) Prove that the map from v to z is passive if $z(0) = 0$.
 (e) Prove that the map from v to F is passive if $z(0) = 0$ and $0 \leq \sigma_1(v) \leq 4\sigma_0 g(v)/|v|$.

□

EXERCISE 6.3

Derive the describing function (v input, F output) for

- (a) Coulomb friction, $F = F_0 \text{sign}(v)$
 (b) Coulomb + linear viscous friction $F = F_0 \text{sign}(v) + F_v v$
 (c) as in b) but with stiction for $v = 0$.

□

EXERCISE 6.4

In Lecture 7 we have studied an adaptive friction compensation scheme for the process (assuming $m = 1$)

$$\begin{aligned}\dot{x} &= v \\ \dot{v} &= -F + u\end{aligned}$$

The friction force F is given by:

$$F = \text{sign}(v).$$

If v is not directly measurable the adaptive friction compensation scheme must be modified. Consider the following double observer scheme:

$$\begin{aligned}\hat{F} &= (z_F + K_F |\hat{v}|) \text{sign}(\hat{v}) \\ \dot{z}_F &= -K_F (u - \hat{F}) \text{sign}(\hat{v}) \\ \hat{v} &= z_v + K_v x \\ \dot{z}_v &= -\hat{F} + u - K_v \hat{v}.\end{aligned}$$

Define the estimation error states

$$\begin{aligned}\hat{e}_v &= v - \hat{v} \\ \hat{e}_F &= F - \hat{F}\end{aligned}$$

For t such that $\hat{v}(t) \neq 0$ show that the state equations for the estimation errors are given by

$$\begin{pmatrix} \dot{\hat{e}}_v(t) \\ \dot{\hat{e}}_F(t) \end{pmatrix} = \begin{pmatrix} -K_v & -1 \\ -K_v K_F & 0 \end{pmatrix} \begin{pmatrix} \hat{e}_v(t) \\ \hat{e}_F(t) \end{pmatrix}$$

Conclude that the linear system is asymptotically stable if $K_v > 0$ and $K_F < 0$.

□

EXERCISE 6.5

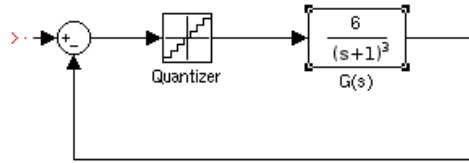

Figure 6.2 System considered in Problem 6.5

- (a) What conclusion does describing function analysis give for the system in Figure 6.2
- (b) Show that the describing function for quantization is given by

$$N(A) = \begin{cases} 0 & A < \frac{D}{2} \\ \frac{4D}{\pi A} \sum_{i=1}^n \sqrt{1 - \left(\frac{2i-1}{2A}D\right)^2} & \frac{2n-1}{2}D < A < \frac{2n+1}{2}D \end{cases}$$

(Hint: Use one of the nonlinearities from Lecture 6 and superposition.)

□

EXERCISE 6.6

Show that a saturation is a passive element.

□

EXERCISE 6.7

Consider the mass-spring system with dry friction

$$\ddot{y} + c\dot{y} + ky + \eta(y, \dot{y}) = 0$$

where η is defined as

$$\eta(y, \dot{y}) = \begin{cases} \mu_k m g \text{sign}(\dot{y}) & \text{for } |\dot{y}| > 0 \\ -ky & \text{for } \dot{y} = 0 \end{cases}$$

Construct the phase portrait and discuss its qualitative behavior. (Hint: Start by sketching the behavior for $\dot{y} > 0$ and $\dot{y} < 0$. Then discuss what happens at $\dot{y} = 0$)

□

EXERCISE 6.8

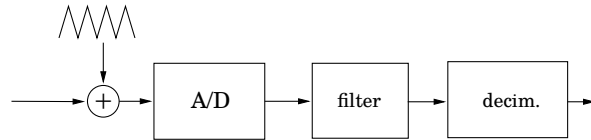

Figure 6.3 The static nonlinearities in Exercise 6.8

The accuracy of a crude A/D converter can be improved by adding a high-frequency dither signal before quantization and lowpass filtering the discretized signal, see Figure 6.3. Compute the stationary value y_0 of the output if the input is a constant u_0 . The dither signal is a triangle wave with zero mean and amplitude $D/2$ where D is the quantization level in the A/D converter.

□

EXERCISE 6.9

For PhD students. Show that the antiwindup scheme in observer form is equivalent to the antiwindup scheme in polynomial form with A_e equal to the observer polynomial (see CCS for definitions).

□

EXERCISE 6.10

For PhD students. Show that the equilibrium point of an unstable linear system preceded with a saturation can not be made globally asymptotically stable with any control law.

□

7. Nonlinear Controller Design

EXERCISE 7.1

In some cases, the main nonlinearity of a system can be isolated to a static nonlinearity on the input. This is, for example, the case when a linear process is controlled using an actuator with a nonlinear characteristic. A simple design methodology is then to design a controller $C(s)$ for the linear process and cancel the effect of the actuator nonlinearity by feeding the computed control through the inverse of the actuator nonlinearity, see Figure 7.1. Compute the

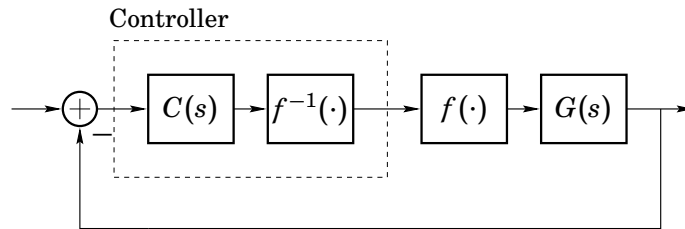

Figure 7.1 Compensation of input nonlinearity by inversion.

inverse of the following common actuator characteristics

- (a) The quadratic (common in valves)

$$f(v) = v^2, \quad v \geq 0$$

- (b) The piecewise linear characteristic

$$f(v) = \begin{cases} k_1 v & |v| \leq d \\ \text{sign}(v)(k_1 - k_2)d + k_2 v & |v| > d \end{cases}$$

with $k_1, k_2 \geq 0$.

Use your result to derive the inverse of the important special case of a dead zone.

- (c) A backlash nonlinearity.

□

EXERCISE 7.2

An important class of nonlinear systems can be written on the form

$$\begin{aligned} \dot{x}_1 &= x_2 \\ \dot{x}_2 &= x_3 \\ &\vdots \\ \dot{x}_n &= f(x) + g(x)u \end{aligned}$$

Assume that the full state x is available for measurement.

- (a) Find a feedback

$$u = h(x, v)$$

that renders the closed loop system from the new input v to the state linear. What conditions do you have to impose on $f(x)$ and $g(x)$ in order to make the procedure well posed?

- (b) Apply this procedure to design a feedback for the inverted pendulum

$$\begin{aligned}\dot{x}_1 &= x_2 \\ \dot{x}_2 &= a \sin(x_1) + b \cos(x_2)u\end{aligned}$$

that makes the closed loop system behave as a linear system with a double pole in $s = -1$. Is the control well defined for all x ? Can you explain this intuitively?

- (c) One drawback with the above procedure is that it is very sensitive to modelling errors. Show that this is the case by designing a linearizing feedback for the system

$$\dot{x} = x^2 + u$$

that makes the closed loop system linear with a pole in -1 . Apply the suggested control to the system

$$\dot{x} = (1 + \epsilon)x^2 + u$$

and show that some solutions are unbounded irrespectively of $\epsilon \neq 0$.

□

EXERCISE 7.3

Consider a linear system

$$\begin{aligned}\dot{x}_1 &= ax_2 + bu \\ \dot{x}_2 &= x_1\end{aligned}$$

with nominal parameter values $a = 1$, $b = 1$. The system equations were obtained by linearization of a nonlinear system, which has the consequence that the parameters a and b vary with operating region.

- (a) One of the design parameters in the design of a sliding mode controller is the choice of sliding surface. Which of the following sliding surfaces will result in a stable sliding mode for the above system?

(i) $\sigma(x) = 2x_1 - x_2$

(ii) $\sigma(x) = x_1 + 2x_2$

(iii) $\sigma(x) = x_1$

- (b) Let the sliding mode be
- $\sigma(x) = x_1 + x_2$
- . Construct a sliding mode controller for the system.

- (c) How large variations in the parameters a and b can the controller designed in (b) tolerate in order to still guarantee a stable closed loop system?

□

EXERCISE 7.4

Consider concentration control for a fluid that flows through a pipe, with no mixing, and through a tank, with perfect mixing. A schematic diagram of the process is shown in Figure 7.2 (left). The concentration at the inlet of the pipe is $c_{in}(t)$. Let the pipe volume be V_d and let the tank volume be V_m . Furthermore, let the flow be q and let the concentration in the tank at the outlet be $c(t)$. A mass balance gives

$$V_m \frac{dc(t)}{dt} = q(c_{in}(t - L) - c(t))$$

where $L = V_d/q$.

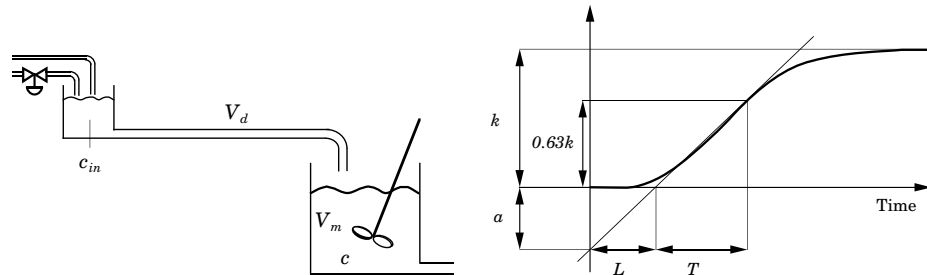

Figure 7.2 Schematic of the concentration control system (left). Parameters in Ziegler-Nichols step response method (right).

- (a) Show that for fixed q , the system from input c_{in} to output c can be represented by a linear transfer function

$$G(s) = \frac{K}{sT + 1} e^{-sL}$$

where L and T depend on q .

- (b) Use Ziegler-Nichols time response method and your model knowledge from (a) to determine a gain scheduled PI-controller from the step response in Figure 7.3. The step response is performed for $q = 1$. Recall that the Ziegler-Nichols step response method relies on the parameters L and $a = KL/T$ defined in Figure 7.2 (right). (The line is tangent to the point where the step response has maximum slope).

Given these process parameters, the method suggest PID controller gains according to Table 7.1.

□

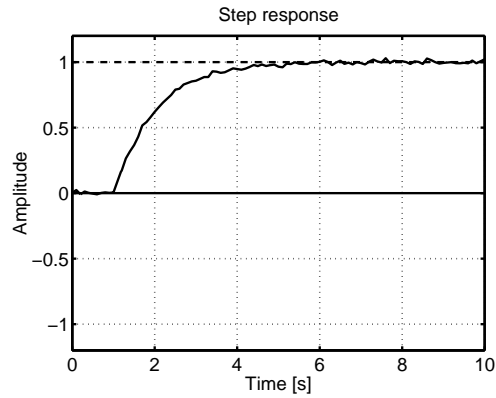

Figure 7.3 Experimental step response for $q = 1$.

Controller	K_p	T_i	T_d
P	$1/a$		
PI	$0.9/a$	$3L$	
PID	$1.2/a$	$2L$	$L/2$

Table 7.1 PID parameters suggested by Ziegler-Nichols step response method.

EXERCISE 7.5 (H)

We have seen how it in many cases can be of interest to control the system into a set, rather than to the origin. One example of this is sliding mode control, where the system state is forced into an invariant set, chosen in such a way that if the state is forced onto this set, the closed loop dynamics are exponentially stable. In this example, we will use similar ideas to design a controller that “swings” up an inverted pendulum from its stable equilibrium (hanging downwards) to its upright position.

Let the pendulum dynamics be given by

$$\begin{aligned}\dot{x}_1 &= x_2 \\ \dot{x}_2 &= -\frac{mgl}{J_p} \sin(x_1) - \frac{ml}{J_p} \cos(x_1)u\end{aligned}$$

A general hint for this exercise: Maple and Matlab Symbolic toolbox are handy when dealing with long equations!

- Denote the total energy of the pendulum by E and determine the value E_0 corresponding to the pendulum standing in the upright position.
- Investigate whether the control strategy

$$u = k(E(x) - E_0)\text{sign}(x_2 \cos(x_1))$$

forces the value of E towards E_0 .

- Draw a phase portrait of the system and discuss the qualitative behaviour of the closed loop system. In particular, will the suggested control stabilize the unstable equilibrium point? Use e.g. `pplane` in Matlab (link at the course homepage).

□

EXERCISE 7.6 (H)

Consider the system

$$\begin{aligned}\dot{x}_1 &= x_1 + u \\ \dot{x}_2 &= x_1 \\ y &= x_2\end{aligned}$$

Show that the control law

$$u = -2x_1 - \text{sign}(x_1 + x_2)$$

will make $\sigma(x) = x_1 + x_2 = 0$ into a sliding mode. Determine the equivalent dynamics on the sliding plane $\sigma(x) = 0$.

□

EXERCISE 7.7Minimize $\int_0^1 x^2(t) + u^2(t) dt$ when

$$\begin{aligned}\dot{x}(t) &= u(t) \\ x(0) &= 1 \\ x(1) &= 0\end{aligned}$$

□

EXERCISE 7.8

Neglecting air resistance and the curvature of the earth the launching of a satellite is described with the following equations

$$\begin{aligned}\dot{x}_1 &= x_3 \\ \dot{x}_2 &= x_4 \\ \dot{x}_3 &= \frac{F}{m} \cos u \\ \dot{x}_4 &= \frac{F}{m} \sin u - g\end{aligned}$$

Here x_1 is the horizontal and x_2 the vertical coordinate and x_3 and x_4 are the corresponding velocities. The signal u is the controlled angle. The criterion is to maximize $0.1x_1 + x_2 + 5x_3 + 3x_4$ at the end point. Show that the optimal control signal has the form

$$\tan u = \frac{At + B}{Ct + D}$$

and determine A, B, C, D .

□

EXERCISE 7.9

Suppose more realistically that m and F vary. Let $F = u_2(t)$ be a control signal with limitations

$$0 \leq u_2(t) \leq u_{\max}$$

and let the mass $m = x_5(t)$ vary as

$$\dot{x}_5 = -\gamma u_2$$

Show that

$$\tan u_1 = \begin{cases} \frac{\lambda_4}{\lambda_3} & u_2 > 0 \\ \star & u_2 = 0 \end{cases} \quad \text{and} \quad u_2 = \begin{cases} u_{\max} & \sigma < 0 \\ 0 & \sigma > 0 \\ \star & \sigma = 0, \end{cases}$$

where \star means that the solution is unknown. Determine equations for λ and σ . (You do not have to solve these equations).

□

EXERCISE 7.10

Consider the system

$$\begin{cases} \dot{x}_1 = x_2 \\ \dot{x}_2 = -x_1 - x_2^3 + (1 + x_1)u \end{cases}$$

with initial conditions $x_1(0) = 1, x_2(0) = 1$ and let the criterion be

$$\min \int_0^1 e^{x_1^2} + x_2^2 + u^2 dt.$$

Is the problem normal? Show that extremals satisfy

$$\begin{aligned} \dot{x}_1 &= f_1(x_1, x_2, \lambda_1, \lambda_2) \\ \dot{x}_2 &= f_2(x_1, x_2, \lambda_1, \lambda_2) \\ \dot{\lambda}_1 &= f_3(x_1, x_2, \lambda_1, \lambda_2) \\ \dot{\lambda}_2 &= f_4(x_1, x_2, \lambda_1, \lambda_2) \end{aligned}$$

Determine f_1, f_2, f_3, f_4 . What conditions must λ_1, λ_2 satisfy at the end point?

□

EXERCISE 7.11

Consider the double integrator

$$\begin{aligned} \dot{x}_1 &= x_2 \\ \dot{x}_2 &= u, \quad |u| \leq 1 \end{aligned}$$

with initial value $x(0) = x_0$. We are interested in finding the control that brings the system to rest ($x_1(t_f) = 0, x_2(t_f) = 0$) in minium time. (You may think of this as a way of designing a controller that reacts quickly on set-point

changes) Show that the optimal control is of “bang-bang type” with at most one switch. In other words, the control can be expressed as the feedback law

$$u = \begin{cases} u_{max} & \sigma(x) > 0 \\ -u_{max} & \sigma(x) < 0 \end{cases}$$

Draw a phase portrait of the closed loop system under the optimal control. □

EXERCISE 7.12

Consider the problem of controlling the double integrator

$$\begin{cases} \dot{x}_1 = x_2 \\ \dot{x}_2 = u, \quad |u| \leq 1 \end{cases}$$

from an arbitrary initial condition $x(0)$ to the origin so that the criterion

$$\int_0^{t_f} (1 + |u|) dt$$

is minimized (t_f is the first time so that $x(t_f) = 0$). Show that all extremals are of the form

$$u(t) = \begin{cases} -1 & 0 \leq t \leq t_1 \\ 0 & t_1 \leq t \leq t_2 \\ 1 & t_2 \leq t \leq t_f \end{cases}$$

or

$$u(t) = \begin{cases} 1 & 0 \leq t \leq t_1 \\ 0 & t_1 \leq t \leq t_2 \\ -1 & t_2 \leq t \leq t_f \end{cases}$$

for some t_1, t_2 with $0 \leq t_1 \leq t_2 \leq t_f$. Some time interval can have the length 0. Assume that the problem is normal. □

EXERCISE 7.13

Consider the system

$$\dot{x} = \begin{pmatrix} -5 & 2 \\ -6 & 2 \end{pmatrix} x + \begin{pmatrix} 0 \\ 1 \end{pmatrix} u$$

from $x_0 = 0$ to $x(t_f) = \begin{pmatrix} 1 \\ 1 \end{pmatrix}$ in minimum time with $|u(t)| \leq 3$. Show that the optimal controller is either

$$u(t) = \begin{cases} -3 & 0 \leq t \leq t_1 \\ +3 & t_1 \leq t \leq t_f \end{cases}$$

or

$$u(t) = \begin{cases} +3 & 0 \leq t \leq t_1 \\ -3 & t_1 \leq t \leq t_f \end{cases}$$

for some t_1 .

□

EXERCISE 7.14 (H)

Show that minimum time control of a linear system

$$\dot{x} = Ax + Bu, \quad |u| \leq 1, \quad x(t_f) = 0,$$

leads to extremals of the form

$$u(t) = -\text{sign}(C^T e^{-At} B)$$

for some vector C . What does this say about the optimal input when $A = B = 1$?

□

EXERCISE 7.15

What is the conclusion from the maximum principle for the problem

$$\begin{aligned} \min \int_0^1 u \, dt, \\ \dot{x}_1 = u \\ x_1(0) = 0 \\ x_1(1) = 1 \end{aligned}$$

Explain.

□

EXERCISE 7.16

Consider the control system

$$\ddot{x} - 2(\dot{x})^2 + x = u - 1 \tag{7.1}$$

- Write the system in first-order state-space form.
- Suppose $u(t) \equiv 0$. Find all equilibria and determine if they are stable or asymptotically stable if possible.
- Design a state-feedback controller $u = u(x, \dot{x})$ for (7.1), such that the origin of the closed loop system is globally asymptotically stable.

□

EXERCISE 7.17 (H)

This problem will use the Lyapunov method for design of a control signal which will stabilize a system. Consider the system

$$\begin{aligned} \dot{x}_1 &= -x_1 + x_2 + x_3 \cdot \tan(x_1) \\ \dot{x}_2 &= -x_2^3 - x_1 \\ \dot{x}_3 &= x_2^2 + u \end{aligned} \tag{7.2}$$

Choose $u = u(x_1, x_2, x_3)$ such that the closed loop system becomes globally asymptotically stable.

□

EXERCISE 7.18 (H)

A nonlinear system is given below.

$$\begin{aligned} \dot{x}_1 &= -3x_1 + x_1^3 - x_2 + u \\ \dot{x}_2 &= x_1 - ax_2 \end{aligned}$$

- (a) Determine if possible the (local) stability properties of all equilibrium points to the nonlinear system if $u(t) \equiv 0$ and $a = 1$.
- (b) If $u(t) \equiv 0$ and $a = 0$, prove that the origin is locally asymptotically stable using the Lyapunov function candidate

$$V(x) = \frac{1}{2}x_1^2 + \frac{1}{2}x_2^2$$

combined with the invariant set theorem.

- (c) If $a = 1$, determine a *nonlinear* state feedback control $u = f(x)$ such that the origin is globally asymptotically stable.

□

EXERCISE 7.19

In this problem we are going to examine how to stabilize a system using a bounded control signal $u = \text{sat}_5(v)$, i.e.,

$$u(v) = \begin{cases} 5, & v \geq 5; \\ v, & -5 \leq v \leq 5; \\ -5, & v \leq -5; \end{cases}$$

Your task is to choose the control signal $v = v(x_1, x_2)$, such that the system (7.3)

$$\begin{aligned} \dot{x}_1 &= x_1x_2 \\ \dot{x}_2 &= u \\ u &= \text{sat}_5(v) \end{aligned} \tag{7.3}$$

is globally asymptotically stabilized.

- (a) Indicate the problem of using the Lyapunov candidate

$$V_a = x_1^2 + x_2^2$$

to design a globally stabilized system when using bounded control.

- (b) Instead try with the Lyapunov function candidate

$$V_b = \log(1 + x_1^2) + x_2^2$$

and choose $v(x_1, x_2)$ so that the system is globally asymptotically stabilized.

□

EXERCISE 7.20

Consider the system

$$\begin{aligned}\dot{x}_1 &= x_2 - x_1 \\ \dot{x}_2 &= kx_1^2 - x_2 + u\end{aligned}\tag{7.4}$$

where u is the input and k is an unknown coefficient. Since k is unknown, we can not use the traditional methods to design a stabilizing controller. We therefore try an approach where we estimate k (denoted \hat{k}), and try to prove stability for the whole system (this is often denoted adaptive control). We assume that k is unknown, and changes very slowly.

Find an update law for \hat{k} and a stabilizing controller u . Use the Lyapunov function candidate $V(x_1, x_2, \hat{k}) = \frac{1}{2}(x_1^2 + x_2^2 + (k - \hat{k})^2)$.

□

EXERCISE 7.21

Consider the system

$$\begin{aligned}\dot{x}_1 &= x_1^2 + x_2 \\ \dot{x}_2 &= u\end{aligned}$$

Compute a controller using back-stepping to globally stabilize the origin.

□

EXERCISE 7.22

Consider the system

$$\begin{aligned}\dot{x}_1 &= x_1^2 - x_1^3 + x_2 \\ \dot{x}_2 &= u\end{aligned}$$

(a) Compute a controller using back-stepping to globally stabilize the origin.

b) Draw a phase plane plot using Matlab (ppplane).

□

EXERCISE 7.23

Consider the following nonlinear system:

$$\begin{aligned}\dot{x}_1 &= x_1 + x_2 \\ \dot{x}_2 &= \sin(x_1 - x_2) + u\end{aligned}$$

- (a) Show that the system is on strict feedback form.
 (b) Design a controller based on back-stepping for the system.

□

EXERCISE 7.24

Consider the following nonlinear system:

$$\begin{aligned}\dot{x}_1 &= -\text{sat}(x_1) + x_1^2 x_2 \\ \dot{x}_2 &= x_1^2 + u\end{aligned}$$

- (a) Show that the system is on strict feedback form.
 (b) Design a controller based on back-stepping for the system.

□

EXERCISE 7.25

Consider the following nonlinear system:

$$\begin{aligned}\dot{x}_1 &= x_1 + x_2 \\ \dot{x}_2 &= \sin(x_1 - x_2) + x_3 \\ \dot{x}_3 &= u\end{aligned}$$

Design a controller based on back-stepping for the system. You do not need to substitute back to x_1 , x_2 , x_3 in the computed controller.

□

EXERCISE 7.26

Solve Example 2.1 in <http://www.statslab.cam.ac.uk/~rrw1/oc/oc2013.pdf>.

□

EXERCISE 7.27

Consider the nonlinear optimal control problem

$$\begin{aligned}\text{minimize} \quad & \int_0^1 (x(t)u(t))^2 dt + x(1)^2, \\ \text{subject to} \quad & \dot{x}(t) = x(t)u(t), \quad x(0) = 1.\end{aligned}$$

Solve the problem using dynamic programming by making the ansatz $V(t, x) = q(t)x^2$.

□

Hints*Exercise 7.5*

Use a Lyapunov function argument with $V(x) = (E(x) - E_0)^2$.

Exercise 7.6

Use $V(x) = \sigma^2(x)/2$.

Exercise 7.14

You will most likely need the following relations. If

$$y = e^A x \quad \Rightarrow \quad x = e^{-A} y$$

and

$$(e^A)^T = e^{A^T}$$

Exercise 7.17

Use $V(x_1, x_2, x_3) = \frac{1}{2}(x_1^2 + x_2^2 + x_3^2)$.

Exercise 7.18

Use the Lyapunov function candidate from (b).

Solutions to Chapter 1

SOLUTION 1.1

(a) Choose the angular position and velocity as state variables, *i.e.*, let

$$\begin{aligned}x_1 &= \theta \\x_2 &= \dot{\theta}\end{aligned}$$

We obtain

$$\begin{aligned}\dot{x}_1 &= x_2 \\ \dot{x}_2 &= -\frac{g}{l} \sin(x_1) - \frac{k}{m} x_2\end{aligned}$$

(b) By setting the state derivatives to zero, we obtain

$$\begin{aligned}0 &= x_2 \\ 0 &= -\frac{g}{l} \sin(x_1) - \frac{k}{m} x_2\end{aligned}$$

We find the equilibrium points $(x_1, x_2) = (n\pi, 0)$ with $n = 0, \pm 1, \pm 2, \dots$. The equilibrium points correspond to the pendulum hanging down (n even), or the pendulum balancing in the upright position (n odd).

(c) Linearization gives

$$\frac{d}{dt} \Delta x = \begin{bmatrix} 0 & 1 \\ -\frac{g}{l}(-1)^n & -\frac{k}{m} \end{bmatrix} \Delta x \quad (7.5)$$

The linearized system is stable for even n , and unstable for odd n . We can use Lyapunov's linearization method to conclude that the pendulum is LAS around the lower equilibrium point, and unstable around the upper equilibrium point.

□

SOLUTION 1.2

We choose angular positions and velocities as state variables. Letting $x_1 = q_1$, $x_2 = \dot{q}_1$, $x_3 = q_2$, $x_4 = \dot{q}_2$, we obtain

$$\begin{aligned}\dot{x}_1 &= x_2 \\ \dot{x}_2 &= -\frac{MgL}{I} \sin x_1 - \frac{k}{I}(x_1 - x_3) \\ \dot{x}_3 &= x_4 \\ \dot{x}_4 &= \frac{k}{J}(x_1 - x_3) + \frac{1}{J}u\end{aligned}$$

□

SOLUTION 1.3

(a) Let $x_1 = \delta$, $x_2 = \dot{\delta}$, $x_3 = E_q$ and $u = E_{FD}$. We obtain

$$\begin{aligned}\dot{x}_1 &= x_2 \\ \dot{x}_2 &= \frac{P}{M} - \frac{D}{M}x_2 - \frac{\eta_1}{M}x_3 \sin x_1 \\ \dot{x}_3 &= -\frac{\eta_2}{\tau}x_3 + \frac{\eta_3}{\tau} \cos x_1 + \frac{1}{\tau}u\end{aligned}$$

(b) With E_q being constant, the model reduces to

$$\begin{aligned}\dot{x}_1 &= x_2 \\ \dot{x}_2 &= \frac{P}{M} - \frac{D}{M}x_2 - \frac{\eta_1}{M}E_q \sin x_1\end{aligned}$$

which is the pendulum equation with input torque P/M .

(c) The equilibrium points of the simplified equation are given by $\sin x_1 = \frac{P}{\eta_1 E_q}$, $x_2 = 0$.

□

SOLUTION 1.4

(a) Let

$$\dot{x} = Ax + Bu, \quad y = Cx$$

be a state-space realization of the linear system. We have

$$u = r - \psi(t, y) = r - \psi(t, Cx)$$

and hence

$$\dot{x} = Ax - B\psi(t, Cx) + Br, \quad y = Cx$$

(b) To separate the linear dynamics from the nonlinearities, write the pendulum state equations as

$$\begin{aligned}\dot{x}_1 &= x_2 \\ \dot{x}_2 &= -\frac{k}{m}x_2 - \frac{g}{l} \sin(x_1)\end{aligned}$$

and view $\sin(x_1)$ as an input, generated by a nonlinear feedback from $y = x_1$ (Compare with Figure 1.3). Introduce the state vector $x = (x_1, x_2)^T$, and re-write the equations as

$$\dot{x} = \begin{bmatrix} 0 & 1 \\ 0 & -k/m \end{bmatrix} x + \begin{bmatrix} 0 \\ g/l \end{bmatrix} u \quad (7.6)$$

$$y = [1 \ 0] x \quad (7.7)$$

$$u = -\sin(y), \quad (7.8)$$

which is on the requested form.

□

SOLUTION 1.5

(a) Hint: $\dot{e} = -y = -Cz$.(b) The equilibrium points are given by $\dot{z} = 0$ and $\dot{e} = 0$. In steady-state (at an equilibrium point) the amplification of the transfer function is $G(0)$. Denote the steady state error $e^o = \theta_i - \theta_0$. If this should be constant it means that θ_0 is constant (see block diagram of Fig.1.4) and thus $\dot{\theta}_0 = 0$, which is the same signal as the output $y \implies$

$$0 = G(0) \sin e^o$$

from which we obtain

$$e^o = \pm n\pi, \quad n = 0, 1, 2, \dots$$

(c) For $G(s) = 1/(\tau s + 1)$, we take $A = -1/\tau$, $B = 1/\tau$ and $C = 1$. Then

$$\begin{aligned} \dot{z} &= -\frac{1}{\tau}z + \frac{1}{\tau} \sin e \\ \dot{e} &= -z \end{aligned}$$

Now, let $x_1 = e$ and $x_2 = -z$, so that

$$\begin{aligned} \dot{x}_1 &= x_2 \\ \dot{x}_2 &= -\frac{1}{\tau}x_2 - \frac{1}{\tau} \sin x_1, \end{aligned}$$

which is the pendulum model with $g/l = k/m = 1/\tau$.

□

SOLUTION 1.6

Let $G_{PID}(s)$ be the transfer function for the PID controller. In order to find the feedback interconnection form, the first step is to define the input and output of the non-linearity. In this case F is the output and v is the input. This implies, that the required linear system G_l has as its input F and as its output v . By the help of the block-diagram one finds

$$G_l(s) = \frac{s}{ms^2 + G_{PID}(s)}$$

Hence, the whole system is a feedback interconnection of the linear system $G_l(s)$ and the non-linearity $F(v)$. Observe, the feedback interconnection form is usually defined such that, the linear part receives a negative feedback from the non-linearity.

□

SOLUTION 1.7

The requested form

$$\begin{aligned} U(s) &= -G_l(s)V(s) \\ v(t) &= \text{sat}(u) \end{aligned}$$

is obtained with

$$G_l(s) = \frac{G_{fb}G_p - G_{aw}}{1 + G_{aw}}$$

□

SOLUTION 1.8

(a) Introduce $x_1 = y$, $x_2 = \dot{y}$, $x_3 =$ “valve input”, then

$$\begin{aligned}\dot{x}_1 &= x_2 \\ \dot{x}_2 &= -2x_2 - x_1 + f(x_3) \\ \dot{x}_3 &= r - x_1\end{aligned}$$

(b) For a constant input r the equilibrium point is given by $x = (r, 0, \pm\sqrt{r})$. The linearization for $x = (r, 0, \sqrt{r})$ has

$$A = \begin{bmatrix} 0 & 1 & 0 \\ -1 & -2 & 2\sqrt{r} \\ -1 & 0 & 0 \end{bmatrix}.$$

The characteristic equation is given by

$$\lambda^2(\lambda + 2) + 2\sqrt{r} + \lambda = 0.$$

The condition for stability of $\lambda^3 + a\lambda^2 + b\lambda + c$ is $a, b, c > 0$ and $ab > c$. Similar calculations for $x = (r, 0, -\sqrt{r})$ gives that that equilibrium point is never locally stable. Hence we get local stability if $0 < r < 1$. An alternative approach is to compute that the gain margin of $\frac{1}{s(s+1)^2}$ is 2. Since the linearization of the valve has gain $f'(x_3) = 2x_3 = 2\sqrt{r}$ we get stability for $r < 1$.

(c) More realistic is that the flow is zero.

□

SOLUTION 1.9

The linearization is given by

$$\ddot{x} = -k_1x + u,$$

which is controllable. Hence the system is nonlinear locally controllable.

□

SOLUTION 1.10

The linearized system is not controllable. The system is however nonlinear locally controllable. This can be seen directly from the definition as follows: We must show that we can drive the system from $(0, 0, 0)$ to a near by state (x_T, y_T, θ_T) using small control signals u_1 and u_2 . By the sequence $u = (u_1, u_2) = (0, \epsilon_1), u = (\epsilon_1, 0), u = (0, -\epsilon_1), u = (-\epsilon_2, 0)$ (or in words: “turn left, forward, turn right, backwards”) one can move to the state $(0, y_T, 0)$. Then apply $(\epsilon_3, 0)$ and then $(0, \epsilon_4)$ to end up in (x_T, y_T, θ_T) . For any time $T > 0$ this movement can be done with small ϵ_i if x_T, y_T and θ_T are small.

□

SOLUTION 1.11

Same solution as in 1.10, except that you have to find a movement afterwards that changes Ψ without changing the other states. This can be done by the sequence: L-F-R-B-R-F-L-B where F=forward, B=backwards, L=turn left, R=turn right.

□

SOLUTION 1.12

The linearized system at (x_0, u_0) is

$$\begin{aligned}\dot{x}_1 &= u \\ \dot{x}_2 &= x_1\end{aligned}$$

The controllability matrix

$$W_c = \begin{bmatrix} 1 & 0 \\ 0 & 1 \end{bmatrix}$$

has full rank. Since the linearized system is controllable the nonlinear system is also locally controllable at (x_0, u_0) .

□

SOLUTION 1.13

See lecture slides. Why does $\max(\text{abs}(y(:)))$ not give the correct stationary output amplitude?.

□

SOLUTION 1.14

See lecture slides.

□

SOLUTION 1.15

See lecture slides.

□

SOLUTION 1.16

With $a = 0.02$ and $w = 100\pi$ we get local stability for $l \in [0.044, 1.9]$.

□

SOLUTION 1.17

(a) $x = 0$, and if $r > 1$ also $x = (\sqrt{b(r-1)}, \sqrt{b(r-1)}, r-1)$ and $x = (-\sqrt{b(r-1)}, -\sqrt{b(r-1)}, r-1)$.

(b) The linearization around $x = 0$ is

$$\dot{x} = \begin{pmatrix} -\sigma & \sigma & 0 \\ r & -1 & 0 \\ 0 & 0 & -b \end{pmatrix}$$

with characteristic polynomial $(s+b)(s^2 + (\sigma+1)s + \sigma(1-r))$. A second order monic polynomial has all roots in the left half plane iff it has positive coefficients, hence $x = 0$ is LAS when $0 < r < 1$, $(\sigma, b, r > 0$ by default).

□

Solutions to Chapter 2

SOLUTION 2.1

(a) The equilibrium points are

$$(x_1, x_2) = (0, 0), (\sqrt{6}, 0), (-\sqrt{6}, 0),$$

which are stable focus, saddle, and saddle, respectively.

(b) The equilibrium points are

$$(x_1, x_2) = (0, 0), (-2.5505, -2.5505), (-7.4495, -7.4495),$$

which are stable node, saddle point, and stable focus, respectively.

(c) The equilibrium points are

$$(x_1, x_2) = (0, 0), (1, 0), (0, 1),$$

which are unstable node, saddle, and stable node, respectively.

(d) The equilibrium is

$$(x_1, x_2) = (0, 0),$$

which is an unstable focus.

(e) The equilibrium point is

$$(x_1, x_2) = (0, 0),$$

which is a stable focus.

(f) The system has an equilibrium set

$$x_1^2 + x_2^2 = 1$$

and an equilibrium point

$$(x_1, x_2) = (0, 0),$$

which is a stable focus.

□

SOLUTION 2.2

The three equilibrium points are

$$(x_1, x_2) = (0, 0), (\sqrt{ac/b}, a), (-\sqrt{ac/b}, a).$$

The first equilibrium point is a saddle. The other equilibria are stable nodes if $8a \leq c$ and stable focuses if $8a > c$.

□

SOLUTION 2.3

- (a) The system has three equilibrium points

$$(x_1, x_2) = (0, 0), (a, 0), (-a, 0)$$

where a is the first positive root of

$$a - \tan\left(\frac{a}{2}\right) = 0$$

given, approximately, by $a = 2.33$. The origin is a stable node, while the other two equilibria are saddles.

- (b) The system has the origin as a unique equilibrium point, being an unstable focus.
- (c) The system has the equilibrium points

$$(x_1, x_2) = (0, 0), (1, 2), (-1, 2),$$

which are saddle, stable focus, and stable focus, respectively.

□

SOLUTION 2.4

Close to the origin, the saturation element opens in the linear region, and all system are assigned the same closed loop dynamics. Far away from the origin, the influence of the saturated control can be neglected, and the open loop dynamics governs the behaviour.

- (a) System (a) has one stable and one unstable eigenvalue. For initial values close to the stable eigenvector, the state will move towards the origin. For initial values close to the unstable eigenvector, the system diverges towards infinity. This corresponds to the rightmost phase portrait.
- (b) All eigenvalues of system (b) are unstable. Thus, for initial values sufficiently far from the origin, the system state will diverge. This corresponds to the leftmost phase portrait. Note how the region of attraction (the set of initial states, for which the state converges to the origin) is severely limited.
- (c) System (c) is stable also in open loop. This corresponds to the phase portrait in the middle.

□

SOLUTION 2.5

- (a) From the state equations we see that the system has the origin as a unique equilibrium point. To determine the direction of the arrow heads we note that if $x_2 > 0$ then $\dot{x}_1 < 0$, and if $x_2 < 0$ then $\dot{x}_1 > 0$. Hence, x_1 moves to the left in the upper half plane, and to the right in the lower half plane. After marking the arrow heads in the plots we see that the origin is a stable focus. This can be determined by inspection of the vector fields. We also see that the system has two limit cycles. The inner one is unstable and the outer one is stable.

(b) The system has three equilibrium points

$$(x_1, x_2) = (0, 0), (a, 0), (-a, 0),$$

where we can see that $a \approx 4$. As before we the sign of x_2 determines the sign of \dot{x}_1 which makes marking the arrow heads an easy task. After marking the arrow heads we note that the origin is a stable focus, and the points $(a, 0)$, $(-a, 0)$ are saddles (trajectories approach the point from one direction and leave along another direction).

□

SOLUTION 2.6

(a) The equilibrium points are obtained by setting $\dot{x} = 0$. For $K \neq -2$, the origin is the unique equilibrium point. When $K = -2$, the line $x_1 = 2x_2$ is an equilibrium set.

(b) The Jacobian is given by

$$\frac{\partial f}{\partial x}(0) = \begin{bmatrix} -1 & -K \\ 1 & -2 \end{bmatrix}$$

with eigenvalues

$$\lambda = -\frac{3}{2} \pm \sqrt{\frac{1}{4} - K}.$$

Thus, the closed loop system is asymptotically stable about the origin for $K > -2$. Depending on the value of K , we can origin has the following character

$\frac{1}{4} < K$	stable focus
$-2 < K < \frac{1}{4}$	stable node
$K < -2$	saddle.

□

SOLUTION 2.7

The equilibria are given by $\sin x_1^0 = \frac{P}{\eta E_q}$, $x_2^0 = 0$. The characteristic equation for the linearization becomes

$$\lambda^2 + \alpha\lambda + \beta = 0,$$

where $\alpha = \frac{D}{M} > 0$ and $\beta = \frac{\eta E_q}{M} \cos x_1^0$. Depending on α, β the equilibria are stable focus, stable nodes or saddle points.

□

SOLUTION 2.8

- (a) Just plug into the system dynamics.
- (b) To determine stability of the limit cycle, we introduce polar coordinates. With $r \geq 0$:

$$\begin{aligned}x_1 &= r \cos(\theta) \\x_2 &= r \sin(\theta)\end{aligned}$$

Differentiating both sides gives

$$\begin{pmatrix} \dot{x}_1 \\ \dot{x}_2 \end{pmatrix} = \begin{pmatrix} \cos(\theta) & -r \sin(\theta) \\ \sin(\theta) & r \cos(\theta) \end{pmatrix} \begin{pmatrix} \dot{r} \\ \dot{\theta} \end{pmatrix}$$

Inverting the matrix gives:

$$\begin{pmatrix} \dot{r} \\ \dot{\theta} \end{pmatrix} = \frac{1}{r} \begin{pmatrix} r \cos(\theta) & r \sin(\theta) \\ -\sin(\theta) & \cos(\theta) \end{pmatrix} \begin{pmatrix} \dot{x}_1 \\ \dot{x}_2 \end{pmatrix}$$

Plugging in the state equations results in:

$$\dot{r} = r(1 - r^2) \tag{7.9}$$

$$\dot{\theta} = -1 \tag{7.10}$$

We see that the the only equilibrium points to (7.9) are 0 and 1 (since $r \geq 0$). Linearizing around $r = 1$ (i.e. the limit cycle) gives:

$$\dot{\tilde{r}} = -2\tilde{r}$$

which implies that the the $r = 1$ is a locally asymptotically stable equilibrium point of (7.9). Hence the limit cycle is stable.

Alternative for determining stability of limit cycle We can also use LaSalle's invariance principle: Define

$$V(x) = (x_1^2 + x_2^2 - 1)^2$$

Then

$$\dot{V} = \dots = -(x_1^2 + x_2^2 - 1)^2(x_1^2 + x_2^2) \leq 0 \quad \forall x \in \mathbb{R}^2 \tag{7.11}$$

Therefore

$$\Omega = \left\{ x : \frac{1}{2} \leq \|x\|_2 \leq 2 \right\}$$

is a compact invariant set. Let

$$E = \{x \in \Omega : \dot{V}(x) = 0\}$$

From (7.11) we see that

$$E = \{x : \|x\|_2 = 1\}$$

which is the limit cycle itself. By the invariance principle we conclude that all trajectories starting in Ω (i.e. in a neighborhood of the limit cycle) will converge to E (the limit cycle). The limit cycle is thus stable.

(c) In compact notation we have:

$$\dot{x} = f(x)$$

Introduce $\tilde{x}(t) = x(t) - x_0(t)$ as the deviation from the nominal trajectory. We have

$$\dot{x} = \dot{x}_0 + \dot{\tilde{x}}$$

and the first order Taylor expansion of f around $x_0(t)$ is given by

$$\dot{x} = f(x_0) + \frac{\partial f(x_0)}{\partial x} \tilde{x}$$

So

$$\dot{x}_0 + \dot{\tilde{x}} = f(x_0) + \frac{\partial f(x_0)}{\partial x} \tilde{x}$$

Since $x_0(t)$ is a solution to the state equation (verify!) we have $\dot{x}_0 = f(x_0)$ and thus

$$\dot{\tilde{x}} = \frac{\partial f(x_0(t))}{\partial x} \tilde{x} = A(t)\tilde{x}$$

where

$$A(t) = \begin{pmatrix} \frac{\partial f_1(x_0(t))}{\partial x_1} & \frac{\partial f_1(x_0(t))}{\partial x_2} \\ \frac{\partial f_2(x_0(t))}{\partial x_1} & \frac{\partial f_2(x_0(t))}{\partial x_2} \end{pmatrix} = \begin{pmatrix} -2 \sin^2(t) & 1 - \sin(2t) \\ -1 - \sin(2t) & -2 \cos^2(t) \end{pmatrix}.$$

□

SOLUTION 2.9

$$\frac{7}{5} \ddot{x} = g \cos(\phi_0) \tilde{\phi} + \frac{2r}{5} \ddot{\phi}$$

□

SOLUTION 2.10

Using the identity

$$(\sin t)^3 = \frac{3}{4} \sin t - \frac{1}{4} \sin 3t$$

we see that $u_0(t) = \sin(3t)$, $y_0(t) = \sin t$ is a nominal solution. The linearization is given by

$$\ddot{y} + 4 \sin^2 t \cdot \tilde{y} = -\frac{1}{3} \ddot{u}.$$

□

SOLUTION 2.11

No solution yet.

□

Solutions to Chapter 3

SOLUTION 3.1

- (a) Linearization about the system around the origin yields

$$A = \frac{\partial f}{\partial x} = 3ax^2$$

Thus, at the origin we have $A = 0$. Since the linearization has one eigenvalue on the imaginary axis, linearization fails to determine stability of the origin.

- (b) $V(0) = 0$, $V(x) \neq 0$ for $x \neq 0$, and $V(x) \rightarrow \infty$ as $x \rightarrow \infty$. Thus, $V(x)$ satisfies the conditions for being a Lyapunov function candidate. Its time derivative is

$$\dot{V}(x) = \frac{\partial V}{\partial x} f(x) = 4ax^6 \quad (7.12)$$

which is negative definite for $a < 0$. The desired result now follows from Lyapunov's global asymptotic stability theorem.

- (c) For $a = 0$, the system is linear and given by

$$\dot{x} = 0$$

The system has solutions $x(t) = x_0$ for all t . Thus, the system is stable. A similar conclusion can be drawn from the Lyapunov function used in (b).

□

SOLUTION 3.2

- (a) Since x_2 is angular velocity, the speed of the pendulum tip is given by lx_2 . Since we assume that all mass is concentrated at the tip the kinetic of the pendulum is

$$\frac{ml^2 x_2^2}{2}.$$

The potential energy is given by mgh , where h is the vertical position of the pendulum relative to some reference level. We choose this reference level by letting $h = 0$ when $x_1 = 0$ (i.e. pendulum in downward position). h can be expressed as

$$h = 1 + \sin\left(x_1 - \frac{\pi}{2}\right) = 1 - \cos(x_1)$$

The pendulum's total energy is then given by

$$V(x) = mgl(1 - \cos(x_1)) + \frac{ml^2}{2}x_2^2$$

We use V as a candidate Lyapunov function. We see that V is positive, and compute the time derivative

$$\frac{dV(x)}{dt} = \sum_i \frac{\partial V}{\partial x_i} \dot{x}_i = mgl \sin(x_1)x_2 + x_2(-mgl \sin(x_1)) = 0$$

V is thus a Lyapunov function. From Lyapunov's theorem, we conclude that the origin is a stable equilibrium point. Since $\dot{V}(x) = 0$, we can also conclude that the origin is *not* asymptotically stable; trajectories starting at a level surface $V(x) = c$, remain on this surface for all future times.

(b) For $k \neq 0$, using $V(x)$ as above, similar calculations give

$$\frac{dV(x)}{dt} = -kl^2 x_2^2$$

$\dot{V}(x)$ is negative semidefinite. It is not negative definite because $\dot{V}(x) = 0$ for $x_2 = 0$. In other words $\dot{V}(x) = 0$ along the x_1 axis. To show local asymptotic stability of the origin define

$$E = \{(x_1, x_2) \mid \dot{V}(x) = 0\} = \{(x_1, x_2) \mid x_2 = 0\}$$

Suppose $x_2 = 0$, and $x_1 \neq 0$. Then by the second state equation we have

$$\dot{x}_2 = -\frac{g}{l} \sin x_1 \neq 0, \quad |x_1| \leq 0.9\pi$$

Thus the largest invariant set in E is $\{0\}$. (Note that since we are considering local asymptotic stability, it is sufficient to consider $|x_1| \leq \pi - \epsilon$ for any sufficiently small positive ϵ .) By LaSalle's invariance principle we conclude that $x \rightarrow 0$.

□

SOLUTION 3.3

With $V = kx^2/2 + \dot{x}^2/2$ we get $\dot{V} = -d\dot{x}^4 \leq 0$. Since $\dot{V} = 0$ only when $\dot{x} = 0$ and the system equation then gives $\ddot{x} = -kx \neq 0$ unless also $x = 0$, we conclude that $x = \dot{x} = 0$ is the only invariant set. The origin is globally asymptotically stable since the Lyapunov function is radially unbounded.

□

SOLUTION 3.4

(a) The eigenvalues of A are $\lambda = -1/2 \pm i\sqrt{3}/2$.

(b) (i) We have

$$\begin{aligned} V(x) &= p_{11}x_1^2 + 2p_{12}x_1x_2 + p_{22}x_2^2 = (\text{if } p_{11} \neq 0) \\ &= p_{11}\left(x_1 + \frac{p_{12}}{p_{11}}x_2\right)^2 + \left(p_{22} - \frac{p_{12}^2}{p_{11}}\right)x_2^2 \end{aligned}$$

If $p_{11} > 0$ and $p_{11}p_{22} - p_{12}^2 > 0$, both terms are non-negative. Moreover, $V(x) \rightarrow \infty$ as $x \rightarrow \infty$, and $V(x) = 0 \Rightarrow x_1 = x_2 = 0$ (This proves the "if"-part). If the conditions on p_{ij} do not hold, it is easy to find x such that $V(x) < 0$ (proving the "only if"-part).

(ii) We want to solve

$$\begin{bmatrix} 0 & 1 \\ -1 & -1 \end{bmatrix} \begin{bmatrix} p_{11} & p_{12} \\ p_{12} & p_{22} \end{bmatrix} + \begin{bmatrix} p_{11} & p_{12} \\ p_{12} & p_{22} \end{bmatrix} \begin{bmatrix} 0 & -1 \\ 1 & -1 \end{bmatrix} = \begin{bmatrix} -1 & 0 \\ 0 & -1 \end{bmatrix}$$

Reading off the elements, we see that

$$\begin{cases} 2p_{12} & = -1 \\ p_{22} - p_{11} - p_{12} & = 0 \\ -2p_{12} - 2p_{22} & = -1 \end{cases}$$

which has the solution $p_{11} = 1.5$, $p_{12} = -0.5$ and $p_{22} = 1$. P is a positive definite matrix.

(c) Use the Matlab command `lyap(A', eye(2))`.

□

SOLUTION 3.6

(a) The mistake is that V is not radially unbounded. The student has forgotten to check that $\lim_{x \rightarrow \infty} V(x) = \infty$. In fact,

$$V(x_1, x_2) = \frac{x_1^2}{1 + x_1^2} + \frac{1}{2}x_2^2$$

so that $\lim_{x \rightarrow \infty} V(x) = 1$. Consequently, V is not radially unbounded.

(b) No, the problem is not that the student was not clever enough to find a Lyapunov function. There is no Lyapunov function, since the system is not globally stable. Let's show this now. In part (a), you may have noticed that $\dot{V} = 0$ for all x . In other words, V is an "integral" of the motion; the trajectories lie on the curves of constant value of V , *i.e.*, we have

$$V(x) = \frac{1}{2}x_2^2 + \frac{x_1^2}{1 + x_1^2} = V(x_0) = c$$

If $c > 1$ then $x(t)$ cannot change sign, since

$$x_2^2 = c - \frac{x_1^2}{1 + x_1^2} \geq c - 1$$

In this case, we have $|x_2| \geq \sqrt{c-1}$. Since $\dot{x}_1 = x_2$, it follows that $|x_1| \rightarrow \infty$ as $t \rightarrow \infty$. Roughly speaking, if the system starts with more initial stored energy than can possibly be stored as potential energy in the spring, the trajectories will diverge.

□

SOLUTION 3.7

Find the equilibrium points for the system.

$$\begin{aligned} \dot{x}_1 = 0 &= 4x_1^2x_2 - f_1(x_1)(x_1^2 + 2x_2^2 - 4) \\ \dot{x}_2 = 0 &= -2x_1^3 - f_2(x_2)(x_1^2 + 2x_2^2 - 4), \end{aligned}$$

(a) No equilibrium point satisfies $x_1 \neq 0$ and $x_2 \neq 0$. If $x_1 = 0$ the second state equation implies that $(0, 0)$ and $(0, \pm\sqrt{2})$ are equilibrium points. If $x_1 \neq 0$, then $x_2 = 0$, and the second equation implies

$$2x_1^3 = 0 \Rightarrow x_1 = 0$$

The equilibrium points are thus $(0, 0)$ and $(0, \pm\sqrt{2})$.

(b) The system equations on the set E simplifies to

$$\begin{aligned}\dot{x}_1 &= 4x_1^2x_2 \\ \dot{x}_2 &= -2x_1^3,\end{aligned}$$

since $x_1^2 + 2x_2^2 - 4 = 0$ on E . The set E is invariant since

$$\frac{d}{dt}(x_1^2 + 2x_2^2 - 4) = 2x_1\dot{x}_1 + 4x_2\dot{x}_2 = 2x_1^34x_2 + 4x_2(-2x_1^3) = 0.$$

for any $x \in E$. I.e. if $x(T) \in E$ for some T then $x(t) \in E$ for all $t \geq T$. The motion on this invariant set is given by

$$\begin{aligned}\dot{x}_1 &= 4x_2 \cdot x_1^2 \\ \dot{x}_2 &= -2x_1 \cdot x_1^2\end{aligned}$$

(c) Use the squared distance to the set E as Lyapunov candidate

$$V(x) = (x_1^2 + 2x_2^2 - 4)^2.$$

Since $\dot{V} = \dots = -4(x_1^2 + 2x_2^2 - 4)(x_1f(x_1) + 2x_2f(x_2))$ we conclude that $\dot{V} < 0$ everywhere except on E and $x = 0$. Since E is an ellipsoid with the origin as its center, the state converges to E from any initial condition except the origin (since distance to the E must decrease). I.e. all trajectories except $x \equiv 0$ tend to E .

(d) The set E is NOT a limit cycle, as the two equilibrium points $(x_1, x_2) = (0, \pm\sqrt{2})$ belong to this set. Any trajectory moving along the invariant set will eventually end up in either $(x_1, x_2) = (0, +\sqrt{2})$ or $(x_1, x_2) = (0, -\sqrt{2})$.

□

SOLUTION 3.8

Verify that $V(0) = 0$, $V(x) > 0$ for $x \neq 0$ and $V(x) \rightarrow \infty$ for $\|x\| \rightarrow \infty$. Now,

(a) We have

$$\begin{aligned}\frac{d}{dt}V(x_1, x_2) &= 8x_1\dot{x}_1 + 4x_2\dot{x}_2 + 16x_1^3\dot{x}_1 = \\ &= 8x_1x_2 + 4x_2(-2x_1 - 2x_2 - 4x_1^3) + 16x_1^3x_2 = \\ &= -8x_2^2\end{aligned}$$

Since $\dot{V}(x) \leq 0$, we conclude global stability.

(b) The Lyapunov function has $\dot{V}(x) = 0$ for $x_2 = 0$. For $x_2 = 0$, we obtain

$$\dot{x}_2 = -2x_1(2 + x_1^2).$$

which implies that if x_2 should remain zero, then x_1 has also to be zero. The invariance theorem from the lectures can now be used to conclude global asymptotic stability of the origin.

□

SOLUTION 3.9

- (a) Introduce the state vector $x = (x_1, x_2)^T = (y, \dot{y})^T$. The system dynamics can now be written as

$$\begin{aligned}\dot{x}_1 &= x_2 \\ \dot{x}_2 &= -\text{sat}(2x_1 + 3x_2)\end{aligned}$$

Consider the Lyapunov function

$$V(x_1, x_2) = \frac{1}{2}x_2^2 + \frac{1}{2} \int_0^{2x_1+3x_2} \text{sat}(z) dz$$

It is straight forward to show that V is positive definite. (Can x go to infinity without V going to infinity?). Now,

$$\begin{aligned}\frac{d}{dt}V(x_1, x_2) &= x_2\dot{x}_2 + \frac{1}{2}\text{sat}(2x_1 + 3x_2)(2x_1 + 3x_2) \\ &= -\frac{3}{2}(\text{sat}(2x_1 + 3x_2))^2 \\ &\leq 0\end{aligned}$$

By Lyapunov theory, the system is globally stable. Further,

$$\begin{aligned}\dot{V}(x) = 0 &\Rightarrow \dot{x}_2 = \text{sat}(2x_1 + 3x_2) = 0 \\ &\Rightarrow x_1(t) = x_2(t) = 0, \quad \forall t\end{aligned}$$

which implies global asymptotic stability.

- (b) No. These conditions would imply global exponential stability. This can not be achieved by the system, since in the saturated regions we have

$$\ddot{y} = \pm 1.$$

- (c) Try a slight modification of the procedure suggested in (a).
(d) No. So don't work too long on this one.

□

SOLUTION 3.10

The derivative of the suggested Lyapunov function is

$$\dot{V}(x) = -2x_2 \max\{0, x_1\} \max\{0, x_2\} \geq 0$$

with equality for $x_1 \leq 0$, $x_2 \leq 0$ or both. Thus, the Lyapunov function derivative is negative in the first quadrant and zero elsewhere in the plane. When the Lyapunov function derivative is zero, we have

$$\begin{aligned}\dot{x}_1 &= x_2 \\ \dot{x}_2 &= -x_1\end{aligned}$$

This system has solutions

$$\begin{aligned}x_1(t) &= A \cos(t) + B \sin(t) \\ x_2(t) &= B \cos(t) - A \sin(t)\end{aligned}$$

The trace of x_1, x_2 is a circle, then if A and B are both nonzero, $x_1(t) > 0$ and $x_2(t) > 0$ for some t . This implies that the only solution of $\dot{V}(x) = 0$ is $x(t) = 0$ for all t . By LaSalle's theorem, this system is globally asymptotically stable. □

SOLUTION 3.11

(a)

$$P = 0.5 \begin{bmatrix} 1 & 0 \\ 0 & 1 \end{bmatrix}$$

solves the Lyapunov equation with Q as the identity matrix.

Alternative:

$$\dot{V} = -x_1^2 + x_1x_2 - x_1x_2 - x_2^2 = -(x_1^2 + x_2^2)$$

(b) We have

$$\begin{aligned} \dot{V}(x) &= x^T (A^T P + P A)x + 2x^T P g(x_2) = \\ &= -x_1^2 - x_2^2 + x_2 g(x_2) < 0 \end{aligned}$$

since the contribution from the $x_2 g(x_2)$ -term is non-positive under the stated conditions.

(c) We have

$$\dot{V}(x) = -x_1^2 - x_2^2 + x_2^4$$

which is negative for $x_2^2 < 1$. One might be tempted to consider the whole strip

$$E = \{x : |x_2| < 1\}$$

as a region of attraction. However, a couple of simulations show that this is misleading, see Figure 7.4. The problem is that it is possible for V to decrease even if $|x_2|$ increases as long as $|x_1|$ decreases sufficiently fast. By taking a level set contained in E we guarantee that this does not happen. Since the level sets $0.5(x_1^2 + x_2^2) = \gamma$ are circles, we conclude that the largest level set is

$$\Omega = \{x : V(x) < \frac{1}{2}\}.$$

The unit circle is thus a guaranteed region of attraction. □

SOLUTION 3.12

(a) The origin is locally asymptotically stable, since the linearization

$$\frac{d}{dt}\tilde{x} = \begin{bmatrix} 0 & -1 \\ 1 & -1 \end{bmatrix} \tilde{x}$$

is asymptotically stable. A Lyapunov function for the system can be found by solving the Lyapunov equation

$$A^T P + P A = -I,$$

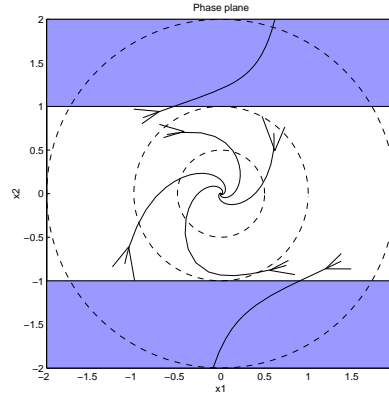

Figure 7.4 Trajectories of the nonlinear system and level surfaces of $V(x) = 0.5x^T x$. The region of attraction is the unit circle.

which has the unique solution

$$P = \begin{bmatrix} 1.5 & -0.5 \\ -0.5 & 1 \end{bmatrix} \quad (7.13)$$

(You can solve Lyapunov equations in Matlab using the command `lyap(A.', -eye(2))`; . Note the transpose on the A matrix, due to Matlab's definition of the command `lyap`.

- (b) Since the Lyapunov function in (a) is positive for all x , we just have to find the largest domain in which the derivative of the Lyapunov function is negative. Introduce the polar coordinates (r, θ) by

$$\begin{aligned} x_1 &= r \cos \theta \\ x_2 &= r \sin \theta \end{aligned}$$

We get

$$\dot{V}(r, \theta) = -r^2 + r^4 \cos^2 \theta \sin \theta (2 \sin \theta - \cos \theta) \leq -r^2 + 0.861r^4$$

which is negative for $r^2 < 1/0.861$. Using this, together with $\lambda_{\min}(P) \geq 0.69$, we choose

$$c = 0.8 < \frac{0.69}{0.861} = 0.801$$

The set $\{x | x^T P x \leq c\}$ is an estimate of the region of attraction.

□

SOLUTION 3.13

- (a) For $|2x_1 + x_2| \leq 1$, we have

$$\dot{x} = \begin{bmatrix} 0 & 1 \\ -1 & -1 \end{bmatrix} x. \quad (7.14)$$

The system matrix is ass. stable. Hence, the origin is locally asymptotically stable.

(b) We have $V(x) > 0$ in the first and third quadrant.

$$\dot{V}(x) = \dot{x}_1 x_2 + x_1 \dot{x}_2 = x_1^2 - x_1 \text{sat}(2x_1 + x_2) + x_2^2.$$

Now, let us evaluate $\dot{V}(x)$ on the strip $x_1 x_2 = c$ and suppose that $c > 0$ is chosen so large that the saturation is active, *i.e.*, $|2x_1 + x_2| > 1$. By inspection of the dynamics, we see that for sufficiently large c , no trajectories can escape from the first quadrant. We can therefore use the following Lyapunov argument. Consider the Lyapunov function derivative

$$\dot{V}(x) = x_1^2 - x_1 + \frac{c^2}{x_1^2}.$$

If $c \geq 1$, $\dot{V}(x)$ is positive for all $x_1 \geq 0$. Hence, all trajectories starting in the first quadrant to the right of the curve $x_1 x_2 = c$ cannot cross the curve. Consequently, they cannot reach the origin.

(c) It follows from (b) that the origin is not globally asymptotically stable. □

SOLUTION 3.14

- (a) Use V as a Lyapunov function candidate and let u be generated by the nonlinear state feedback

$$u = -\left(\frac{\partial V}{\partial x}\psi(x)\right)$$

- (b) Intentionally left blank. □

SOLUTION 3.5

Use convexity wrt K . □

SOLUTION 3.16

- (a) Integration of the equality $\frac{d}{d\sigma}f(\sigma x) = \frac{\partial f}{\partial x}(\sigma x) \cdot x$ gives the equation

$$f(x) = \int_0^1 \frac{\partial f}{\partial x}(\sigma x) \cdot x d\sigma.$$

We get

$$\begin{aligned} x^T P f(x) + f^T(x) P x &= x^T P \int_0^1 \frac{\partial f}{\partial x}(\sigma x) x d\sigma + \int_0^1 x^T \left[\frac{\partial f}{\partial x}(\sigma x) \right]^T d\sigma P x \\ &= x^T \int_0^1 \left\{ P \frac{\partial f}{\partial x}(\sigma x) + \left[\frac{\partial f}{\partial x}(\sigma x) \right]^T P \right\} d\sigma x \leq -x^T x \end{aligned}$$

- (b) Since P is positive definite, $V(x)$ is clearly positive semidefinite. To show that it is positive definite, we need to show that $f(x) = 0$ only when $x = 0$. But the inequality proved in (a) shows that if $f(p) = 0$ then

$$0 \leq -p^T p.$$

- (c) Suppose that f is bounded, i.e. that $\|f(x)\| \leq c$ for all x . Then

$$\|x^T P f + f^T P x\| \leq 2c \|P\| \|x\|.$$

But this contradicts the inequality in (a) as $\|x\| \rightarrow \infty$.

- (d) We have shown that V is positive definite and radially unbounded. Moreover

$$\dot{V} = \dot{x}^T \left[\frac{\partial f}{\partial x} \right]^T P f + f^T P \frac{\partial f}{\partial x} \dot{x} = f^T \left[P \frac{\partial f}{\partial x}(x) + \left(\frac{\partial f}{\partial x}(x) \right)^T P \right] f \leq -\|f(x)\|^2.$$

Hence $\dot{V}(x) < 0$ for all $x \neq 0$. Thus, the origin is globally asymptotically stable. □

SOLUTION 3.17

Assume the linearization $A = \frac{\partial f}{\partial x}$ of f is asymptotically stable. Then the equation

$$PA + A^T P = -I,$$

has a solution $P > 0$. (To prove that $P = \int_0^\infty e^{A^T s} e^{As} ds > 0$ is such a solution integrate both sides of

$$\frac{d}{ds} e^{A^T s} e^{As} = A^T e^{A^T s} e^{As} + e^{A^T s} e^{As} A$$

from 0 to ∞ .) All conditions of Krasovskii's method are then satisfied and we conclude that the nonlinear system is asymptotically stable. The instability result is harder. □

SOLUTION 3.18

The system is given by

$$\begin{aligned} \dot{x}_1 &= x_2 =: f_1 \\ \dot{x}_2 &= -x_2 + Kg(e) = -x_2 + Kg(-x_1) =: f_2. \end{aligned}$$

Following the hint we put $V = f^T(x)Pf(x)$. Direct calculations give

$$\dot{V} = f^T \begin{pmatrix} -6p_{12}Kx_1^2 & p_{11} - p_{12} - 3Kp_{22}x_1^2 \\ p_{11} - p_{12} - 3Kp_{22}x_1^2 & 2(p_{12} - p_{22}) \end{pmatrix} f.$$

With

$$P = \begin{pmatrix} 1 & 1 \\ 1 & 2 \end{pmatrix}$$

we get $\dot{V} \leq 0$ if $3Kx_1^2 < 1$. Hence the system is locally stable. Actually one gets $\dot{V} < 0$ if $3Kx_1^2 < 1$ unless $x_1 = 0$. The invariant set is $x_1 = x_2 = 0$. From LaSalle's theorem the origin is hence also locally *asymptotically* stable. □

Solutions to Chapter 4

SOLUTION 4.1

See the Figure 7.5.

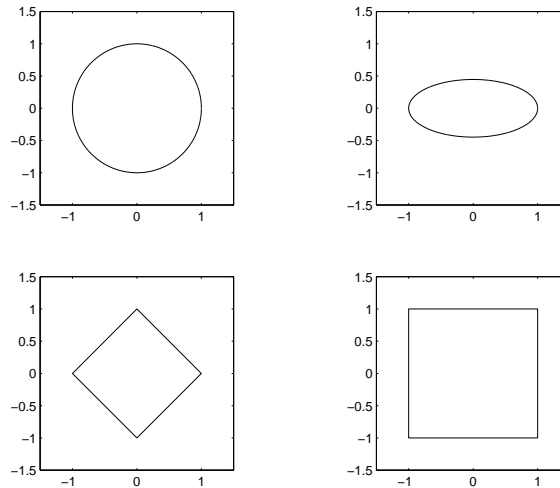

Figure 7.5 The balls $B(0, 1)$ in Exercise 4.1

□

SOLUTION 4.2

- (a) What are the restrictions that we must impose on the nonlinearities so that we can apply the various stability theorems?

The Nyquist Criterion $\psi(y)$ must be a linear function of y , i.e., $\psi(y) = k_1 y$ for some constant k_1 .

The Circle Criterion $\psi(y)$ must be contained in some sector $[k_1, k_2]$.

Small Gain Theorem $\psi(y)$ should be contained in a symmetric sector $[-k_2, k_2]$. The gain of the nonlinearity is then k_2 .

The Passivity Theorem states that one of the systems must be strictly passive and the other one passive. Here we consider the case where ψ is strictly passive. Let $y = \psi(u)$. According to the definition in the lecture notes a system is strictly passive if

$$(u, y)_T \geq \epsilon(\|u\|_T^2 + \|y\|_T^2)$$

for all u and $T > 0$ and some $\epsilon > 0$. This requires $\psi(0) = 0$, and since ψ is static:

$$y(t)u(t) \geq \epsilon(u(t)^2 + y(t)^2) \quad \forall t \geq 0$$

The last inequality can also be written as

$$\left(\frac{u}{y} - \frac{1}{2\epsilon}\right)^2 \leq \frac{1}{4\epsilon^2} - 1$$

Since $y = 2\epsilon u$, and $y = \frac{1}{2\epsilon}u$ satisfy this inequality for all $\epsilon \in (0, \frac{1}{2})$, then

$$2\epsilon u \leq y \leq \frac{1}{2\epsilon}u$$

also satisfy the inequality. We conclude that ψ is strictly passive if ψ belongs to the sector $[\epsilon, \frac{1}{\epsilon}]$ for some small $\epsilon > 0$.

These conditions are illustrated in Figure 7.6.

- (b) If the above restrictions hold, we get the following conditions on the Nyquist curve

The Nyquist Criterion The Nyquist curve should not encircle the point $-1/k_1$.

The Circle Criterion If $0 \leq k_1 \leq k_2$, the Nyquist curve should neither encircle nor intersect the disc defined by $-1/k_2, -1/k_1$. If $k_1 < 0 < k_2$ G should stay inside the disc.

Small Gain Theorem The Nyquist curve has to be contained in a disc centered at the origin, with radius $1/k_2$.

The Passivity Theorem Since we assumed that ψ is strictly passive, G needs to be passive. Thus the Nyquist curve has to stay in the right half-plane, $Re(G(i\omega)) \geq 0$.

These conditions are illustrated in Figure 7.7.

- (c) The Passivity theorem and Small gain theorem can handle dynamic nonlinearities.

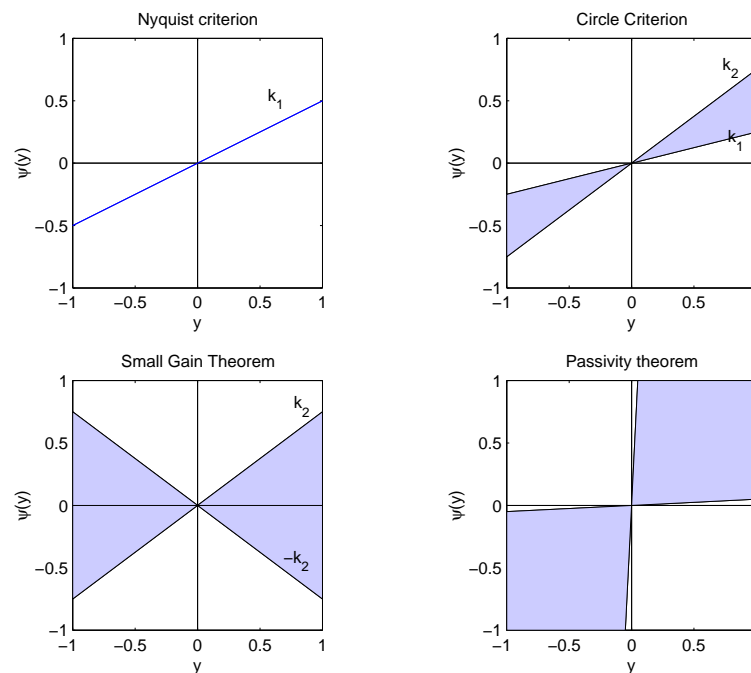

Figure 7.6 Sector conditions on memoryless nonlinearity.

□

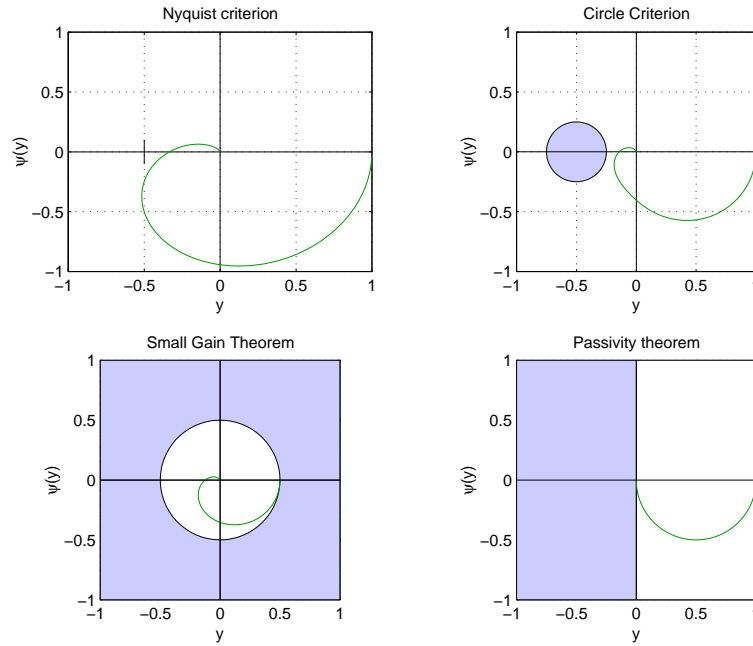

Figure 7.7 Conditions on Nyquist curve matched to sector conditions on memoryless nonlinearity.

SOLUTION 4.3

- The systems belong to the sectors $[0, 1]$, $[0, \infty]$ and $[-1, \infty]$ respectively.
- Only the saturation nonlinearity (the leftmost nonlinearity) has finite gain, which is equal to one. The other two nonlinearities have infinite gain.
- The nonlinearity is passive if $uy \geq 0$. That is if and only if the curve is contained in the first and third quadrants. The saturation and the sign nonlinearity are passive. The rightmost nonlinearity is *not* passive.

□

SOLUTION 4.4

Since the linear part of the system is Hurwitz, we are free to use all versions of the circle criterion.

- In order to guarantee stability of a nonlinearity belonging to a symmetric sector $[-\alpha, \alpha]$, the Nyquist curve has to stay strictly inside a disk centered at the origin with radius $1/\alpha$. We may, for instance, take $\alpha = 0.25 - \epsilon$ for some small $\epsilon > 0$.
- The Nyquist curve lies inside the disk $D(-1.35, 4.35)$. Thus, stability can be guaranteed for all nonlinearities in the sector $-0.23, 0.74$. (NOTE: The disk $D(x_1, x_2)$ is defined as the disk with diameter $|x_1 - x_2|$ which crosses the real axis in x_1 and x_2 .)
- We must find β such that the Nyquist plot lies outside of a half-plane $Re(G(i\omega)) < -1/\beta$. A rough estimate from the plot is $\beta = 1.1$.

□

SOLUTION 4.5

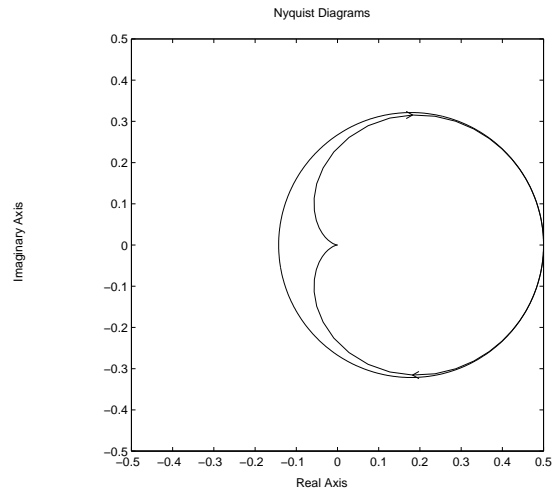

Figure 7.8 The Nyquist curves for the system in Exercise 4.6a, and the circle corresponding to $k_1 = -2$, $k_2 = 7$.

The open loop system has one unstable pole, and we are restricted to apply the first or fourth version of the circle criterion. In this example, we can place a disk with center in -3 and with radius 0.75 , and apply the first version of the Nyquist criterion to conclude stability for all nonlinearities in the sector $[0.27, 0.44]$.

□

SOLUTION 4.6

- (a) The circle with $k_1 = -2$, $k_2 = 7$ does not intersect the Nyquist curve (see Figure 7.8). Hence the sector $(-2, 7)$ suffices. As always there are many other circles that can be used (The lower limit can be traded against the upper limit).
- (b) The Nyquist diagram is a circle with midpoint in -0.5 and radius 0.5 , see Figure 4.5. Since the open system has two unstable poles the Nyquist curve should encircle the disc twice. Choosing the circle that passes through $-1/k_1 = -1 + \epsilon$ and $-1/k_2 = -\epsilon$, we conclude by the Bode-diagram, that the loop is stable for the sector $[\frac{1}{1-\epsilon}, 1/\epsilon]$,

□

SOLUTION 4.7

(a) Introduce $y = Cx$ and $u = \delta y = \psi(y)$, then

$$\begin{aligned}\dot{x} &= Ax + Bu \\ y &= Cx\end{aligned}$$

$$Y(s) = CX(s) = C(sI - A)^{-1}BU(s) = G(s)U(s)$$

(b) ψ satisfies:

$$\begin{aligned}\|\psi(y)\|_2^2 &= \int_0^\infty |\delta(t)y(t)|^2 dt \leq \int_0^\infty |\delta(t)|^2 |y(t)|^2 dt \\ &\leq \sup_t |\delta(t)|^2 \int_0^\infty |y(t)|^2 dt = \sup_t |\delta(t)|^2 \|y\|_2^2 \leq \|y\|_2^2\end{aligned}$$

Thus $\gamma(\psi) \leq 1$. The gain of the linear system is $\gamma(G)$. Then, according to the Small Gain Theorem the feedback connection is BIBO-stable if $\gamma(G) < 1$. Since the gain of a linear system is given by

$$\gamma(G) = \sup_{\omega \in (0, \infty)} |G(i\omega)| < 1 \quad (7.15)$$

the desired results follow directly.

- (c) Only the leftmost Nyquist curve shows a system with gain greater than one. Thus, systems corresponding to the middle and the rightmost Nyquist curve are guaranteed to give a BIBO stable feedback loop.
- (d) Follows from the definition of gain for linear time invariant MIMO systems.

□

SOLUTION 4.8

(a) `>> A=[1 10; 0 1];svd(A)`
`ans =`
`10.0990`
`0.0990`

(b)

$$\begin{aligned}\sigma_1(AB) &= \sup_x \frac{\|ABx\|}{\|x\|} = \sup_x \left(\frac{\|ABx\|}{\|Bx\|} \cdot \frac{\|Bx\|}{\|x\|} \right) \\ &= \sup_y \left(\frac{\|Ay\|}{\|y\|} \cdot \sup_x \frac{\|Bx\|}{\|x\|} \right) = \sigma_1(A)\sigma_1(B)\end{aligned}$$

□

SOLUTION 4.9

The proof follows directly from the definition of passivity, since, according to the definition of a storage function

$$\begin{aligned}\langle u, y \rangle_T &= \int_0^T u^T y \, dt \\ &\geq \int_0^T \dot{V}(x) \, dt = V(x(T)) - V(x(0)) = V(x(T))\end{aligned}$$

which is non-negative since $V(x(T)) \geq 0$. Passivity follows.

□

SOLUTION 4.10

The linear system $G(s)$ corresponds to

$$\dot{x} = Ax + Bu, \quad y = B^T Px, \quad x(0) = 0.$$

Let $V = x^T Px$. Then

$$\begin{aligned} \dot{V} &= \dot{x}^T Px + x^T P \dot{x} \\ &= x^T (A^T P + PA)x + 2x^T P Bu = -x^T x + 2y^T u \leq 2y^T u \end{aligned}$$

Integrate and use the fact that $V(0) = 0$, then

$$\int_0^T y^T u dt \geq V(T) - V(0) \geq 0,$$

which proves passivity. □

SOLUTION 4.11

Write the system in state-space form:

$$\begin{aligned} \dot{x} &= -2x + \text{sat}(x) + u, & x(0) &= x_0 \\ y &= x \end{aligned}$$

We try using the quadratic storage function $V(y, u) = y^2/2 = x^2/2$, which is typically a good start when looking for a function to show passivity. First note that

$$\begin{aligned} \frac{d}{dt} V(y, u) &= x(-2x + \text{sat}(x) + u) \\ &= yu - 2x^2 + x\text{sat}(x) \leq yu - x^2 \end{aligned}$$

as

$$x^2 \geq x\text{sat}(x) \geq 0.$$

(a)

$$\frac{d}{dt} V(y, u) \leq yu - x^2 \leq yu$$

Hence, the system is passive.

(b) As we have that $\frac{d}{dt} V(y, u) \leq yu - x^2$ where x^2 is a positive definite function (which is zero only if $x = 0$), it follows that the system also is strictly passive.

(c) You can solve this problem in many ways. Here we will give two alternatives: One using passivity and one based on the circle criterion.

Alternative 1:(Passivity) The controller looks very much as the strictly passive system from (a) and (b), and we therefore introduce a new variable $x_2 = z - \theta$:

$$\begin{aligned} \dot{x}_2 &= \dot{z} - \dot{\theta} = 2(\theta - z) - \text{sat}(\theta - z) - \omega \\ &= -2x_2 + \text{sat}(x_2) - \omega \\ \eta &= z - 2\theta = x_2 - \theta \end{aligned}$$

This will be the block-scheme according to Figure 7.9. We see that the strictly passive system Σ_c with input ω and output x_2 will be feedback connected to another subsystem which consists of the DC-motor with a local feedback with $-\theta$ (coming from one term of η). The transfer function of this subsystem will be

$$\frac{\frac{1}{s+1}}{1 + \frac{1}{s} \frac{1}{s+1}} = \frac{s}{s^2 + s + 1}$$

which is a passive system. We thus have a passive system in feedback with a strictly passive system and therefore, see lecture notes, the closed-loop system will be asymptotically stable, which means that both ω and θ approach 0 as $t \rightarrow \infty$.

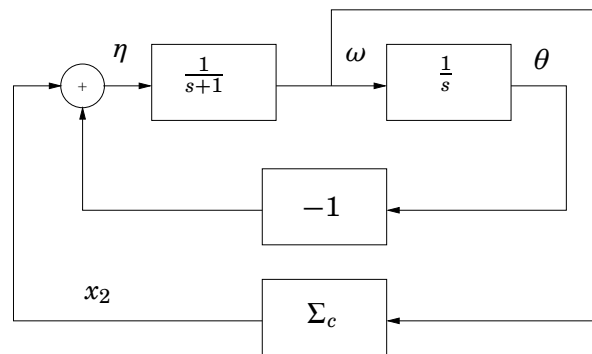

Figure 7.9

Alternative 2:(Circle criterion) With the obvious state vector $x = (\theta, \omega, z)'$, we rewrite the system in the feedback connection form

$$\dot{x} = Ax - B\psi(y) = \begin{bmatrix} 0 & 1 & 0 \\ -2 & -1 & 1 \\ 2 & 0 & -2 \end{bmatrix} x - \begin{bmatrix} 0 \\ 0 \\ 1 \end{bmatrix} \text{sat}([1 \ 0 \ -1] x)$$

The Nyquist curve of the linear system is illustrated in Figure 7.10. Since the Nyquist curve does not intersect the half plane $\text{Re}(G(i\omega)) < -1/2$, we conclude stability for all ψ in the sector $[0, 2]$. Due to that the saturation element lies in the sector $[0, 1]$, we conclude asymptotic stability of the closed loop.

□

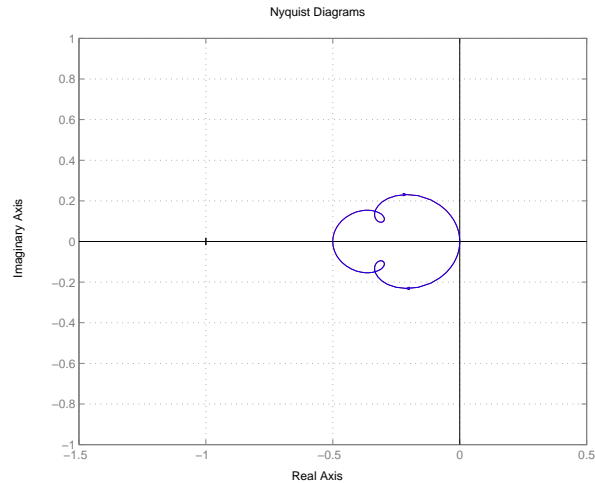

Figure 7.10 Nyquist curve of linear subsystem.

SOLUTION 4.12

(a) We have

$$\begin{aligned}
 \langle y, u \rangle &= \int_0^T y(t)u(t)dt = \\
 &= \int_0^T \{u(t)u_c(t)\}\{H(u(t)u_c(t))\}dt = \\
 &= \int_0^T w(t)H(w(t))dt = \langle w, H(w) \rangle
 \end{aligned}$$

where $w = u_c u$. Since H is passive, the result follows.

(b) We will only consider the case where $\theta^0 = 0$. The case θ^0 is a little trickier, and the discussion about this case is postponed to the course in Adaptive Control.

If $\theta^0 = 0$, the system equations read

$$\begin{aligned}
 e(t) &= G(p)\theta u_c(t) \\
 \dot{\theta}(t) &= -\gamma u_c(t)e(t)
 \end{aligned}$$

In light of exercise (a), we can identify the second equation modeling the signal $w(t) = u_c(t)e(t)$ sent into an integrator with gain γ and postmultiplied by u_c (See the lecture slides for an illustration). This system is passive, and interconnected in a negative feedback loop with the strictly passive system G . Stability now follows from the passivity theorem.

□

SOLUTION 4.13

No solution yet.

□

Solutions to Chapter 5

SOLUTION 5.1

Use the interpretation of describing function as "equivalent gain" and analyse the gains of each non-linearity sectionally. We have 1-b, 2-c, 3-a, 4-d.

□

SOLUTION 5.2

Denote the nonlinearity by f . For memoryless, static nonlinearities, the describing function does not depend on ω , and the describing reduces to

$$N(A) = \frac{b_1(A) + ia_1(A)}{A}$$

where a_1 and b_1 can be computed as

$$a_1 = \frac{1}{\pi} \int_0^{2\pi} f(A \sin(\phi)) \cos(\phi) d\phi \quad (7.16)$$

$$b_1 = \frac{1}{\pi} \int_0^{2\pi} f(A \sin(\phi)) \sin(\phi) d\phi. \quad (7.17)$$

- (a) First, we notice that the saturation is an odd function, which implies that $a_1 = 0$. In order to simplify the computations of b_1 , we set $H = 1$ and note that the saturation can be described as

$$f(A \sin(\phi)) = \begin{cases} A/D \sin(\phi) & 0 \leq \phi \leq \phi_l \\ 1 & \phi_l < \phi < \pi/2 \end{cases}$$

Here, $\phi_l = \arcsin(D/A)$ denotes the value of ϕ where so that f saturates. Now,

$$\begin{aligned} b_1 &= \frac{1}{\pi} \int_0^{2\pi} u(\phi) \sin(\phi) d\phi = \\ &= \frac{4}{\pi} \int_0^{\pi/2} u(\phi) \sin(\phi) d\phi = \\ &= \frac{4}{\pi} \left(\int_0^{\phi_l} A/D \sin^2(\phi) d\phi + \int_{\phi_l}^{\pi/2} \sin(\phi) d\phi \right) = \\ &= \frac{4}{\pi} \left(\int_0^{\phi_l} A/(2D)(1 - \cos(2\phi)) d\phi + \int_{\phi_l}^{\pi/2} \sin(\phi) d\phi \right) = \\ &= \frac{4}{\pi} (A/(2D)(\phi_l - \sin(\phi_l) \cos(\phi_l)) + \cos(\phi_l)) = \\ &= \frac{2A}{D\pi} \left(\phi_l + \frac{D}{A} \cos(\phi_l) \right) \end{aligned}$$

Thus, the describing function for the normalized saturation is

$$N(A) = \frac{2}{D\pi} \left(\phi_l + \frac{D}{A} \cos(\phi_l) \right)$$

Now, using the calculation rule $N_{\alpha f}(A) = \alpha N_f(A)$, we find that for the saturation under consideration we have

$$N(A) = \frac{2H}{D\pi} \left(\phi_l + \frac{D}{A} \cos(\phi_l) \right)$$

(b) We see that the nonlinearity is a superposition of a linear function

$$g(e) = \frac{H}{D}e$$

and the nonlinearity $-f(e)$ with $f(e)$ as in (a). Using the fact that a linear function $g(e) = ke$ has describing function $N(A) = k$, and the superposition rule $N_{f+g}(A) = N_f(A) + N_g(A)$, we find

$$N(A) = \frac{H}{D} \left(1 - \frac{2}{\pi} \left\{ \phi_l + \frac{D}{A} \cos(\phi_l) \right\} \right)$$

(c) Noting that this nonlinearity can be written as the sum of the two nonlinearities in (a) and (b), we arrive at the describing function

$$N(A) = \frac{2(\alpha - \beta)}{\pi} \left(\phi_l + \frac{D}{A} \cos(\phi_l) \right) + \beta.$$

□

SOLUTION 5.3

Let the input to the relay be

$$u(t) = A \sin(\omega t) = A \sin(\phi)$$

The output of the relay is then

$$y(\phi) = \begin{cases} -H & 0 < \phi < \phi_0 \\ H & \phi_0 < \phi < \pi + \phi_0 \\ -H & \pi + \phi_0 < \phi < 2\pi \end{cases}$$

where $\phi_0 = \arcsin(D/A)$. We get

$$\begin{aligned} a_1 &= \frac{1}{\pi} \int_0^{2\pi} y(\phi) \cos(\phi) d\phi \\ &= \frac{1}{\pi} \int_0^{\phi_0} (-H) \cos(\phi) d\phi + \frac{1}{\pi} \int_{\phi_0}^{\pi+\phi_0} H \cos(\phi) d\phi + \frac{1}{\pi} \int_{\pi+\phi_0}^{2\pi} (-H) \cos(\phi) d\phi \\ &= -\frac{4H}{\pi} \sin(\phi_0) \end{aligned}$$

and

$$\begin{aligned} b_1 &= \frac{1}{\pi} \int_0^{2\pi} y(\phi) \sin(\phi) d\phi \\ &= \frac{1}{\pi} \int_0^{\phi_0} (-H) \sin(\phi) d\phi + \frac{1}{\pi} \int_{\phi_0}^{\pi+\phi_0} H \sin(\phi) d\phi + \frac{1}{\pi} \int_{\pi+\phi_0}^{2\pi} (-H) \sin(\phi) d\phi \\ &= \frac{4H}{\pi} \cos(\phi_0) \end{aligned}$$

We obtain

$$N(A) = \frac{4H}{\pi A} (\cos(\phi_0) - i \sin(\phi_0))$$

The identity $\cos(z) = \sqrt{1 - \sin^2(z)}$ gives the desired result.

□

SOLUTION 5.4

Follows from the integration rule

$$\int f(ax)dx = \frac{1}{a}F(ax)$$

where $F(x) = \int f(x)dx$.

□

SOLUTION 5.5

We have

$$\frac{\phi(x)}{x} < \frac{\phi(a)}{a}, \quad x < a.$$

and thus

$$\begin{aligned} \Phi(a) &= \frac{2}{a\pi} \int_0^\pi \phi(a \sin(\theta)) \sin(\theta) d\theta \\ &< \frac{2}{a\pi} \int_0^\pi a \sin(\theta) \frac{\phi(a)}{a} \sin(\theta) d\theta \\ &= \phi(a) \frac{2}{a\pi} \int_0^\pi \sin^2(\theta) d\theta = \phi(a)/a \end{aligned}$$

□

SOLUTION 5.6

The describing function is

$$N(A) = k_1 + 3A^2 k_3/4$$

Note, however, that the output $y(T)$ of the nonlinearity for the input $e(t) = A \sin(\phi)$ is

$$\begin{aligned} y(t) &= A^2 k_2/2 + (k_1 A + 3A^3 k_2/4) \sin(\phi) \\ &\quad - A^2 k_2/2 \cdot \cos(2\phi) - A^3 k_3/4 \cdot \sin(3\phi) \end{aligned}$$

We conclude that the term $k_2 x_2^2$ does not influence $N(A)$. Still, we can not just apply the describing function method, since there is a bias term. If the linear system has integral action, the presence of a constant offset on the input will have a very big influence after some time.

□

SOLUTION 5.7

- (a) When the saturation works in the linear range, we have the closed loop dynamics

$$G(s) = \frac{-5s}{s^2 + (1-5)s + 25}$$

which is unstable. Thus, the state can not remain small. In saturation, on the other hand, the nonlinearity generates a constant (“step”) input to the system. The final value theorem then gives

$$\lim_{t \rightarrow \infty} y(t) = \lim_{s \rightarrow 0} \frac{-5s}{s^2 + s + 25} = 0$$

The observation that $y(t) \rightarrow 0$ contradicts the assumption that the nonlinearity remains saturated.

- (b) We should investigate intersection of the Nyquist curve and $-1/N(A)$. Since $N(A) \in (0, 1]$, $-1/N(A)$ lies in the interval $(-\infty, -1]$.

The frequency response of the system is

$$G(i\omega) = \frac{-i5\omega}{25 - \omega^2 + i\omega} = \frac{-5\omega^2}{(25 - \omega^2)^2 + \omega^2} + i \frac{5\omega(\omega^2 - 25)}{(25 - \omega^2)^2 + \omega^2} \quad (7.18)$$

which intersects the negative real axis for $\omega' = 5$ rad/s. The value of $G(i\omega') = -5$. Thus, there will be an intersection. The frequency of the oscillation is estimated to 5 rad/s, the amplitude can be given by

$$-\frac{1}{N(A)} = G(i\omega') = -5 \Rightarrow N(A) = 0.2$$

From Figure 5.6 we see that $A = 6$.

- (c) From (7.18) we see that the $Re(G) \leq 0$ for all $\omega \in \mathbb{R}$, and that $Im(G) < 0$ for $\omega \in [0, 5)$, and $Im(G) \geq 0$ for $\omega \geq 5$. The Nyquist curve of the system is shown in Figure 7.11. The function $-1/N(A)$ is situated on the negative real axis between $-\infty$ and -1 , the latter is marked by a small line. The Nyquist curve encircles the points $Re(G(i\omega)) > -5$, indicating increased oscillation amplitude. The points to the left of the intersection are not encircled, indicating stability and a decaying oscillation amplitude. We can thus expect a stable limit cycle.

□

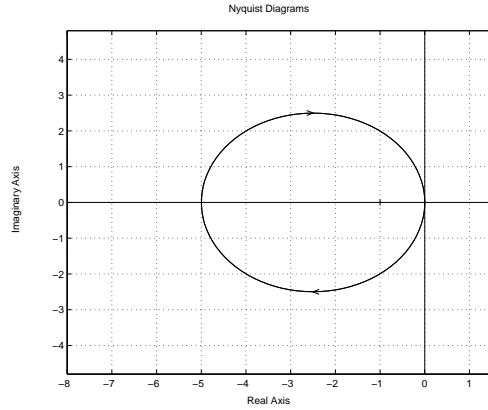

Figure 7.11 Nyquist curve and $-1/N(A)$ for oscillator example.

SOLUTION 5.8

- (a) Introduce $\theta_0 = \arcsin(a/A)$ and proceed similarly to the saturation nonlinearity.
 (b) The describing function has maximum for

$$A^* = \sqrt{2}a$$

which gives

$$N(A^*) = \frac{2}{\pi a}$$

The Nyquist curve crosses the negative real axis for $\omega = \sqrt{2}$, for which the gain is $G(i\sqrt{2}) = -2/3$. Thus, we should expect no oscillations if

$$a > \frac{4}{3\pi}.$$

□

SOLUTION 5.9

- (a) The describing function for a relay with amplitude D is given by

$$N(A) = \frac{4D}{\pi A}$$

$-1/N(A)$ lies on the negative real axis. If the Nyquist curve intersects the negative real axis, the describing function methods will predict a sustained oscillation

$$-\frac{4D}{\pi A}|G(i\omega_u)| = -1$$

Thus, given the amplitude A of the oscillation, we estimate the ultimate gain as

$$K_u = 1/|G(i\omega_u)| = \frac{4D}{\pi A}$$

The ultimate period is the period time of the oscillations

$$T_u = 2\pi/\omega$$

(b) From the simulation, we estimate the amplitude $A = 0.6$ which gives $K_u \approx 2.12$. The ultimate period can be estimated directly from the plot to be $T_u \approx 2$. Note that the estimates have good correspondence with the analytical results (which require a full process model)

□

SOLUTION 5.10
No solution yet.

□

SOLUTION 5.11
No solution yet.

□

SOLUTION 5.12
No solution yet.

□

SOLUTION 5.13
No solution yet.

□

Solutions to Chapter 6

SOLUTION 6.1

We would like to write the system equations as

$$\begin{aligned}v &= G(s)(-u) \\ u &= \phi(v)\end{aligned}$$

where $\phi(\cdot)$ denotes the saturation. Block diagram manipulations give

$$\begin{aligned}v &= u - \left(\frac{AR}{A_w A} + \frac{BS}{A_w A} \right) u \\ &= \left(\frac{AR + BS}{AA_w} - 1 \right) (-u) = G(s)(-u)\end{aligned}$$

Since the saturation element belongs to the sector $[0, 1]$, we invoke the circle criterion and conclude stability if the Nyquist curve of $G(i\omega)$ does not enter the half plane $Re(G(i\omega)) < -1$. This gives the desired condition. □

SOLUTION 6.2

The model is given by

$$\frac{dz}{dt} = v - \frac{|v|}{g(v)} z \tag{7.19}$$

$$F = \sigma_0 z + \sigma_1(v) \frac{dz}{dt} + F_v v \tag{7.20}$$

(a) For constant velocity $v \neq 0$, the stationary point z^* is

$$z^* = \frac{g(v)}{|v|} v = g(v) \text{sign}(v).$$

z^* is asymptotically stable since

$$\frac{d(z - z^*)}{dt} = -\frac{|v|}{g(v)} (z - z^*),$$

where $g(v) \geq 0$.

(a) For any constant velocity, $v \neq 0$, (7.19) converges to $z = g(v) \text{sign}(v)$, and F therefore converges to

$$F = \sigma_0 g(v) \text{sign}(v) + F_v v$$

(b) Following the hint, we consider $V(z) = z^2$. Along trajectories of the model, we have

$$\begin{aligned}\dot{V} &= 2z \left(v - \frac{|v|}{g(v)} z \right) \\ &\leq 2|z||v| \left(1 - \frac{|z|}{g(v)} \right)\end{aligned}$$

which is non-positive if $|z|/g(v) \geq 1$. Since $0 \leq g(v) \leq a$, we see that for

$$|z(t)| \geq a$$

we have $\dot{V} \leq 0$. We conclude that

$$\Omega = \{z | z^T z < a^2\}$$

is invariant. In other words, all trajectories that start within Ω remain there for all future times. The set Ω provides a bound on the state $z(t)$.

(c) Consider the storage function $V(z) = z^2/2$. We have

$$zv = z \frac{dz}{dt} + \frac{|v|}{g(v)} z^2 \geq z \frac{dz}{dt} = \dot{V}(t)$$

and passivity follows from the discussion in (+).

(d) We have

$$Fv = F_v v^2 + (\sigma_1 \dot{z} + \sigma_0 z) \left(\dot{z} + \frac{|v|}{g(v)} z \right) \quad (7.21)$$

$$\geq \sigma_1 \dot{z}^2 + \frac{|v|}{g(v)} \sigma_0 z^2 + \left(\frac{|v|}{g(v)} \sigma_1 + \sigma_0 \right) z \dot{z} \quad (7.22)$$

In the expression above we recognize the term $\sigma_0 z \dot{z}$ as the time derivative of the storage function $V(z) = \sigma_0 z^2/2$. Next, we separate out the storage function derivative and make a completion of squares to estimate the additional terms

$$Fv \geq \sigma_0 z \dot{z} + \sigma_1 \dot{z}^2 + \sigma_0 \frac{|v|}{g(v)} z^2 + \sigma_1 \frac{|v|}{g(v)} z \dot{z} \quad (7.23)$$

$$= \dot{V} + \sigma_1 \left(\dot{z} + \frac{|v|}{2g(v)} z \right)^2 + \left(\sigma_0 \frac{|v|}{g(v)} - \sigma_1 \left(\frac{|v|}{2g(v)} \right)^2 \right) z^2 \quad (7.24)$$

Since the second term is non-negative, we have

$$Fv \geq \dot{V}$$

and thus passivity if

$$\sigma_0 - \sigma_1 \frac{|v|}{4g(v)} > 0$$

This concludes the proof. □

SOLUTION 6.3

(a) The describing function for a relay has been derived on Lecture 6 to be

$$N(A) = \frac{4F_0}{\pi A}$$

- (b) Using the superposition property of describing functions for static nonlinearities $N_{f+g} = N_f + N_g$, and the fact that for a scalar gain $y = ku$ the describing function is $N(A) = k$, we obtain

$$N(A) = F_v + \frac{4F_0}{\pi A}$$

- (c) Stiction is a point-wise phenomenon (occurring for $v = 0$) with finite amplitude, and has no influence on the integral calculations involved in the describing function computation. The describing function is therefore the same as in (b). □

SOLUTION 6.4

The process is given by

$$\begin{aligned}\dot{x} &= v \\ \dot{v} &= -F + u\end{aligned}$$

The velocity is observed through

$$\begin{aligned}\hat{v} &= z_v + K_v x \\ \dot{z}_v &= -\hat{F} + u - K_v \hat{v}\end{aligned}$$

where \hat{F} denotes the estimated friction force, estimated by the observer

$$\begin{aligned}\hat{F} &= (z_F + K_F |\hat{v}|) \text{sign}(\hat{v}) \\ \dot{z}_F &= -K_F (u - \hat{F}) \text{sign}(\hat{v})\end{aligned}$$

Defining the observer errors

$$\begin{aligned}e_v &= v - \hat{v} \\ e_F &= F - \hat{F}\end{aligned}$$

we obtain the observer dynamics

$$\begin{aligned}\dot{e}_v &= \dot{v} - \dot{\hat{v}} = \dot{v} - \dot{z}_v - K_v \dot{x} = -F + u - (-\hat{F} + u - K_v \hat{v}) - K_v v \\ &= -F + \hat{F} - K_v (v - \hat{v}) = -e_F - K_v e_v \\ \dot{e}_F &= \dot{F} - \dot{\hat{F}} = \dot{F} - \dot{z}_F \text{sign}(\hat{v}) - K_F \hat{v} = \dot{F} - (-K_F (u - \hat{F})) \\ &\quad - K_F (-\hat{F} + u - K_v \hat{v} + K_v v) = \dot{F} - K_F K_v (v - \hat{v}) = \dot{F} - K_F K_v e_v\end{aligned}$$

The term \dot{F} is zero (except at zero velocity where it is not well defined). Putting $\dot{F} = 0$, we obtain

$$\begin{bmatrix} \dot{e}_v \\ \dot{e}_F \end{bmatrix} = \begin{bmatrix} -K_v & -1 \\ -K_v K_F & 0 \end{bmatrix} \begin{bmatrix} e_v \\ e_F \end{bmatrix} \quad (7.25)$$

with the characteristic equation

$$\lambda(s) = s^2 + K_v s - K_v K_F$$

We conclude that the error dynamics are locally asymptotically stable if

$$\begin{aligned}K_v &> 0, \\ -K_v K_F &> 0\end{aligned}$$

which implies the desired conditions.

□

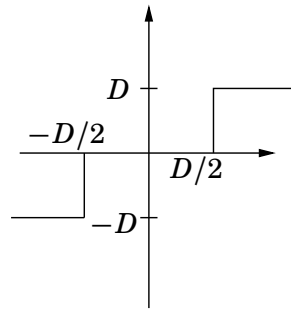

Figure 7.12 The function in 6.5.

SOLUTION 6.5

- (a) The gain margin for the system is $1.33 > 1.27$, thus there should be no limit cycle since the gain margin exceeds that required for the worst-case scenario with quantization.
- (b) We have already (lecture) seen that the describing function for the function in Figure 7.12 is given by

$$N_D(A) = \begin{cases} 0 & A < D/2 \\ \frac{4D}{\pi A} \sqrt{1 - \left(\frac{D}{2A}\right)^2} & A > D/2 \end{cases}$$

Superposition ($N_{f_1+f_2} = N_{f_1} + N_{f_2}$) gives

$$N_Q = N_D + N_{3D} + N_{5D} + \dots + N_{2i+1}$$

which gives the stated describing function $N_Q(A)$ for the quantizer. □

SOLUTION 6.6

We have

$$\langle u, y \rangle_T = \int_0^T u y \, dt = \int_0^T u \text{sat}(u) \, dt \geq 0$$

We conclude passivity from to the definition given in the lecture slides. □

SOLUTION 6.7

No solution yet. □

SOLUTION 6.8

Assume without loss of generality that $0 < u_0 < D/2$. The input to the quantizer is $u_0 + d(t)$ where $d(t)$ is the dither signal. The output y from the quantizer is

$$y(t) = Q(u_0 + d(t)) = \begin{cases} 0 & u_0 + d(t) < D/2 \\ D & u_0 + d(t) > D/2 \end{cases}$$

It is easy to see that $y = D$ during a time interval of length $\frac{u_0}{D}T$, where T is the time period of the dither. The average value of y becomes

$$y_0 = \frac{1}{T} \frac{u_0}{D} T \cdot D = u_0.$$

Hence the dither signal gives increased accuracy, at least if the signal y can be treated as constant compared to the frequency of the dither signal. The method does not work for high-frequency signals y .

□

SOLUTION 6.9

No solution yet.

□

SOLUTION 6.10

No solution yet.

□

Solutions to Chapter 7

SOLUTION 7.1

Let the output of the nonlinearity be u , so that $u = f(v)$.

(a) We have

$$u = v^2, \quad v \geq 0$$

which implies that

$$v = \sqrt{u}, \quad u \geq 0$$

(b) The piecewise linear characteristic

$$u = \begin{cases} k_1 v, & |v| \leq d \\ \text{sign}(v)(k_1 - k_2)d + k_2 v & |v| > d \end{cases}$$

gives the inverse

$$v = \begin{cases} u/k_1, & |u| \leq k_1 d \\ (u - \text{sign}(u)(k_1 - k_2)d)/k_2 & |u| > k_1 d \end{cases}$$

Consider a (unit) dead-zone with slope $k_1 = \epsilon$ in the interval $|v| \leq d$, and slope $k_2 = 1$ otherwise. We obtain the inverse

$$v = \begin{cases} u/\epsilon, & |u| \leq \epsilon d \\ u + \text{sign}(u)(1 - \epsilon)d, & |u| > \epsilon d \end{cases}$$

The dead-zone nonlinearity and its inverse are shown in Figure 7.13.

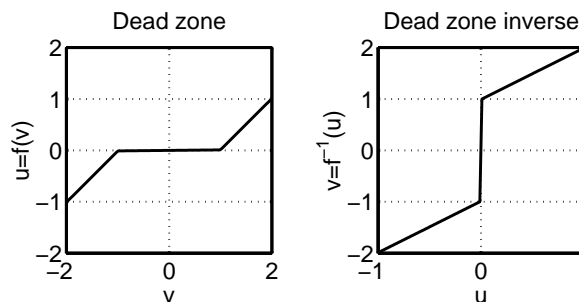

Figure 7.13 Deadzone and its inverse.

(c) See the slides from the lecture of backlash.

□

SOLUTION 7.2

- (a) We notice that all state equation but the last one are linear. The last state equation reads

$$\dot{x}_n = f(x) + g(x)u$$

If we assume that $g(x) \neq 0$ for all x , we can apply the control

$$u = h(x, v) = \frac{1}{g(x)} (-f(x) + Lx + v)$$

renders the last state equation linear

$$\dot{x}_n = Lx + v$$

The response from v to x is linear, and the closed loop dynamics is given by

$$\dot{x} = \begin{bmatrix} 0 & 1 & 0 & 0 & 0 \\ 0 & 0 & 1 & 0 & \dots \\ 0 & 0 & 0 & \ddots & 0 \\ l_1 & l_2 & l_3 & \dots & l_n \end{bmatrix} x + \begin{bmatrix} 0 \\ 0 \\ \vdots \\ 1 \end{bmatrix} v$$

(You may recognize this as the controller form from the basic control course). For the control to be well defined, we must require that $g(x) \neq 0$ for all x .

- (b) The above procedure suggest the control

$$u = \frac{1}{b \cos(x_1)} (-a \sin(x_1) + l_1 x_1 + l_2 x_2 + v)$$

which results in the closed loop system

$$\dot{x} = \begin{bmatrix} 0 & 1 \\ l_1 & l_2 \end{bmatrix} x + \begin{bmatrix} 0 \\ 1 \end{bmatrix} v$$

The system matrix has a double eigenvalue in $s = -1$ if we let

$$l_1 = -1, l_2 = -2$$

The control law is well defined for $x_1 \neq \pi/2$. This corresponds to the pendulum being horizontal. For $x_1 = \pi/2$, u has no influence on the system. Notice how the control “blows up” nearby this singularity. *Extra.* You may want to verify by simulations the behaviour of the modified control

$$u = \text{sat}(h(x, v))$$

for different values of the saturation level.

(c) The above procedure suggest the control

$$u = -x^2 - x + v$$

Letting $v = 0$, we apply the control to the perturbed system

$$\dot{x} = (1 + \epsilon)x^2 - x^2 - x = \epsilon x^2 - x$$

and note that for $x > 1/\epsilon$, we have $\dot{x} > 0$, which implies that the trajectories tend to infinity. Thus, global cancellation is non-robust in the sense that it may require a very precise mathematical model. \square

SOLUTION 7.3

(a) The sliding surface in a sliding mode design is invariant, *i.e.*, if $x(t_s)$ belongs to the sliding surface $\sigma(x) = 0$, at time t_s , then it belongs to the set $\sigma(x) = 0$ for all future times $t \geq t_s$. Thus, it must hold that

$$\sigma(x) = \dot{\sigma}(x) = 0$$

which yields the dynamics on the sliding surface.

(i) We have

$$\dot{\sigma}(x) = 2\dot{x}_1 - \dot{x}_2 = 2\dot{x}_1 - x_1 = 0$$

The third equality implies that $x_1(t) \rightarrow \pm\infty$ on the sliding surface. Thus, forcing this surface to be a sliding mode would give unstable solutions.

(ii) Similarly as above

$$\dot{\sigma}(x) = \dot{x}_1 + 2\dot{x}_2 = \dot{x}_1 + 2x_1 = 0$$

Thus, the equivalent dynamics along this surface satisfy $\dot{x}_1 = -2x_1$ and is hence asymptotically stable.

(iii) We have

$$\dot{\sigma}(x) = \dot{x}_1 = 0$$

The dynamics on this sliding surface would thus be stable, but not asymptotically stable.

(b) According to the lecture slides, the sliding mode control law is

$$u = -\frac{p^T A x}{p^T B} - \frac{\mu}{p^T B} \text{sign}(\sigma(x))$$

Where the sliding surface is given by

$$\sigma(x) = p^T x = 0$$

Thus, in this example we have $p^T = [1 \ 1]$ and

$$u = -(x_1 + x_2) - \mu \text{sign}(x_1 + x_2)$$

- (c) According to the robustness result of the sliding mode controller presented on the lecture, the above controller will force the system toward the sliding mode if μ is chosen large enough, and if $\text{sign}(p^T \hat{B}) = \text{sign}(p^T B)$, which implies $\text{sign}(\hat{b}) = \text{sign}(b)$. Since the nominal design has $\hat{b} = 1$, we must have

$$b > 0 \quad (7.26)$$

It remains to check that the dynamics of the sliding mode remains stable. (Otherwise, we could have a situation where the controller forces the state onto the sliding mode, but where the sliding mode dynamics are unstable. The state would then tend toward infinity along the sliding mode.) In this case, we can verify that on the sliding mode, we have $\dot{\sigma}(x) = 0$ for all values of the parameter a .

□

SOLUTION 7.4

- (a) Straightforward manipulations give

$$G(s) = \frac{K}{sT + 1} e^{-sL} = \frac{1}{sV_m/q + 1} e^{-sV_d/q}$$

- (b) The step response gives parameters $a = 0.9$, $L = 1$. Using the results from (a) and $a = KL/T$ we obtain

$$\begin{aligned} a &= V_d/V_m \\ L &= V_d/q \end{aligned}$$

Since the experiment was performed for $q = 1$, we see that $L = V_d$. Now, a gain scheduled PI controller can be constructed using Ziegler-Nichols recommendations as

$$\begin{aligned} K_p &= 0.9/a = 1 \\ T_i &= 3L = 3/q \end{aligned}$$

Here we see that K_p remains constant whereas T_i changes with the flow q .

□

SOLUTION 7.5

- (a) The pendulum energy is given by

$$E(x) = mgl(1 - \cos(x_1)) + \frac{J_p}{2} x_2^2$$

If the energy of the pendulum hanging downwards is taken to be $E(0) = 0$, the energy for $x_1 = \pi$, $x_2 = 0$ is $E_0 = 2mgl$.

- (b) The time derivative of the Lyapunov function candidate reads

$$\begin{aligned} \dot{V}(x) &= 2(E(x) - E_0) \frac{d}{dt} E(x) = \\ &= 2(E(x) - E_0)(mgl \sin(x_1)\dot{x}_1 + J_p x_2 \dot{x}_2) = \\ &= 2(E(x) - E_0)(-mlx_2 \cos(x_1)u) \end{aligned}$$

Applying the suggested control, we obtain

$$\dot{V}(x) = -2kml(E(x) - E_0)^2 x_2 \cos(x_1) \text{sign}(x_2 \cos(x_1)) \leq 0$$

if $k > 0$, with equality attained for $E(x) = E_0$, or $x_2 = 0$ or $x_1 = \pi/2$. The only unwanted invariant manifold is $x_1 = x_2 = 0$.

- (c) The phase portrait of the closed loop system is shown in Figure 7.14. We notice how the state is driven to the set $E(x) = E_0$, and that this set contains no stable equilibrium points. Note that the velocity approaches zero as the pendulum approaches the upright position. Since the equilibrium point is unstable, and the control for this state is zero, the pendulum does not remain in the upright position.

Extra. Feel free to design a stabilizing controller for the upright position (using, for example the results from Exercise 7.2). In particular, how should you switch between the two control strategies to make the system stable? (Some Lyapunov theory will help you on this one)

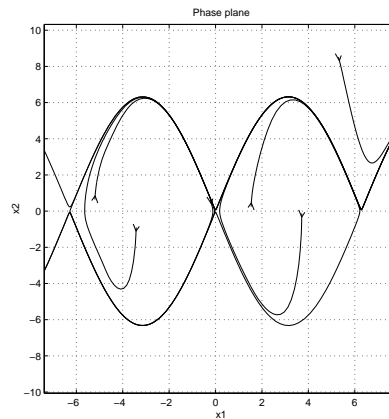

Figure 7.14 Phase plane for pendulum under energy control.

□

SOLUTION 7.6

We get

$$\dot{V} = \sigma(x)\dot{\sigma}(x) = (x_1 + x_2)(2x_1 + u) = (x_1 + x_2)(-\text{sign})(x_1 + x_2) = -|x_1 + x_2|$$

and therefore $\sigma(x) = x_1 + x_2 \rightarrow 0$. The equivalent dynamics is easiest determine by

$$0 = \frac{d}{dt}\sigma(x) = \dot{x}_1 + \dot{x}_2 = x_1 + u + x_1$$

which gives $u = -2x_1$ and hence $\dot{x}_1 = -x_1$ on the sliding plane.

□

SOLUTION 7.7

Hamiltonian.

The general form of the Hamiltonian according to Glad/Ljung (18.34) is

$$H = n_0(x^2 + u^2) + \lambda u$$

Adjoint equation.

$$\dot{\lambda} = -H_x = -2n_0x, \quad \lambda(1) = \text{free}$$

*Optimality conditions.*According to (18.35a) the optimal control signal must minimize the Hamiltonian, so the derivative with respect to u must be zero:

$$0 = H_u = 2n_0u + \lambda \quad \Rightarrow \quad u = -\frac{\lambda}{2n_0}$$

Hence

$$\ddot{x} = \dot{u} = -\frac{\dot{\lambda}}{2n_0} = x$$

The equation $\ddot{x} = x$ has the general solution

$$x(t) = c_1e^t + c_2e^{-t}$$

The boundary conditions $x(0) = 1$ and $x(1) = 0$ give

$$\begin{aligned} c_1 + c_2 &= 1 \\ c_1e + c_2e^{-1} &= 0 \end{aligned}$$

This gives $c_1 = -e^{-2}/(1 - e^{-2})$, $c_2 = 1/(1 - e^{-2})$ and the control signal is

$$u = \dot{x} = c_1e^t - c_2e^{-t}$$

What about the case $n_0 = 0$? Then λ is constant and $\lambda(1) = \mu \neq 0$. Hence $H = \lambda u$ has no minimum in u , so this case gives no solution candidates.

□

SOLUTION 7.8

Hamiltonian. $\phi(x(t_f)) = -0.1x_1(t_f) - x_2(t_f) - 5x_3(t_f) - 3x_4(t_f)$ is the criterion to be minimized. Note that $L = 0$. Setting $\alpha = F/m$, we have

$$H = \lambda_1x_3 + \lambda_2x_4 + \lambda_3\alpha \cos u + \lambda_4(\alpha \sin u - g)$$

Adjoint equation.

$$\begin{aligned} \dot{\lambda}_1 &= 0 \\ \dot{\lambda}_2 &= 0 \\ \dot{\lambda}_3 &= -\lambda_1 \\ \dot{\lambda}_4 &= -\lambda_2 \end{aligned}$$

We know that $\lambda(t_f) = \Phi_x^T(x^*(t_f))$ which gives

$$\begin{aligned}\lambda_1(t_f) &= -0.1 \\ \lambda_2(t_f) &= -1 \\ \lambda_3(t_f) &= -5 \\ \lambda_4(t_f) &= -3\end{aligned}$$

Together with the adjoint equation this gives

$$\begin{aligned}\lambda_1(t) &= -0.1 \\ \lambda_2(t) &= -1 \\ \lambda_3(t) &= -5 + 0.1(t - t_f) \\ \lambda_4(t) &= -3 + t - t_f\end{aligned}$$

Optimality conditions.

Minimizing H with respect to u gives $\frac{\delta H}{\delta u} = 0$ (as u is unbounded)
 $\Rightarrow \lambda_3 \frac{F}{m} \sin(u) = \lambda_4 \frac{F}{m} \cos(u) \Rightarrow \tan(u) = \frac{\lambda_4}{\lambda_3} = \frac{-3+t-t_f}{-5+0.1t-0.1t_f}$ This gives $A = 1$,
 $B = -3 - t_f$, $C = 0.1$, $D = -5 - 0.1t_f$.

□

SOLUTION 7.9

We get

$$\begin{aligned}H &= \lambda_1 x_3 + \lambda_2 x_4 + \lambda_3 \left(\frac{u_2}{x_5} \cos u_1 \right) + \lambda_4 \left(\frac{u_2}{x_5} \sin u_1 - g \right) - \lambda_5 \gamma u_2 \\ &= \sigma(t, u_1) u_2 + \text{terms independent of } u\end{aligned}$$

where $\sigma(t, u_1) = \frac{\lambda_3}{x_5} \cos u_1 + \frac{\lambda_4}{x_5} \sin u_1 - \lambda_5 \gamma$. Since we want to minimize H with respect to u :

$$u_2 = \begin{cases} u_{max} & \sigma < 0 \\ * & \sigma = 0 \\ 0 & \sigma > 0 \end{cases}$$

and

$$\tan u_1 = \begin{cases} \frac{\lambda_4}{\lambda_3} & u_2 > 0 \\ * & u_2 = 0 \end{cases}$$

□

SOLUTION 7.10

The problem is normal, can use $n_0 = 1$. We have

$$\begin{aligned}H &= e^{x_1^2} + x_2^2 + u^2 + \lambda_1 x_2 + \lambda_2 (-x_1 - x_2^3 + (1 + x_1)u) \\ \lambda_1 &= -H_{x_1} = -2x_1 e^{x_1^2} - \lambda_2 (-1 + u) \\ \lambda_2 &= -H_{x_2} = -2x_2 - \lambda_1 + 3x_2^2 \lambda_2 \\ \lambda(1) &= 0\end{aligned}$$

Minimization of H wrt u gives

$$\frac{\partial H}{\partial u} = 0 \Rightarrow 2u + \lambda_2(1 + x_1) = 0 \Rightarrow u = -\frac{\lambda_2}{2}(1 + x_1)$$

($\frac{\partial^2 H}{\partial u^2} = 2 > 0$ hence minimum). This gives

$$\begin{aligned}\dot{x}_1 &= f_1 = x_2 \\ \dot{x}_2 &= f_2 = -x_1 - x_2^3 - \frac{\lambda_2}{2}(1 + x_1)^2 \\ \dot{\lambda}_1 &= f_3 = -2x_1 e^{x_1^2} - \lambda_2(-1 + u) \\ \dot{\lambda}_2 &= f_4 = -2x_2 - \lambda_1 + 3x_2^2 \lambda_2 \\ \lambda_1(1) &= \lambda_2(1) = 0\end{aligned}$$

□

SOLUTION 7.11

Hamiltonian. We have $L = 1$, $\phi = 0$, $\Psi(x) = x$ and t_f free, so

$$H = n_0 + \lambda_1 x_2 + \lambda_2 u$$

Adjoint equation.

$$\begin{cases} \dot{\lambda}_1 = 0 \\ \dot{\lambda}_2 = \lambda_1 \end{cases} \Rightarrow \begin{cases} \lambda_1 = \mu_1 \\ \lambda_2(t) = \mu_1 t + B \end{cases}$$

Optimality conditions.

Minimization of H with respect to u results in

$$u(t) = \begin{cases} 1 & \lambda_2(t) < 0 \\ ? & \lambda_2(t) = 0 \\ -1 & \lambda_2(t) > 0 \end{cases}$$

Since λ_2 is linear, it follows that $u(t) = \pm 1$ with at most one switch. The simplest way to find the switch time is to solve the equations for such input signals. A common trick is to use $\frac{dx_1}{dx_2}$ to find the trajectories.

$$\frac{dx_1}{dx_2} = \frac{x_2}{u} \Rightarrow x_1 + C_1 = \frac{x_2^2}{2u}$$

For $u(t) = 1$ we get

$$x_1 + C_1 = x_2^2/2$$

This gives the phase plane in the Figure 7.15. For $u = -1$ we get

$$x_1 + C_2 = -x_2^2/2$$

This gives the phase plane in the Figure 7.16. Consider especially the two curves for $u = \pm 1$ that pass through the origin ($C_1 = C_2 = 0$). We see that switching has to occur when a curve intersects with another going to the origin, i.e. when $x_1 = -\frac{1}{2}\text{sign}\{x_2\}x_2^2$. To reach the switching curve we need $u(t) = -1$ above the switch curve and $u(t) = 1$ below. We therefore see that the control law is given by

$$u(t) = -\text{sign} \left\{ x_1(t) + \frac{1}{2}\text{sign}\{x_2(t)\}x_2^2(t) \right\}.$$

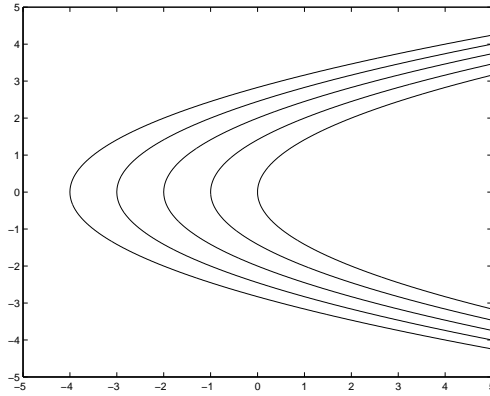

Figure 7.15 Phase plane for $u = 1$. The solution is traveling upwards.

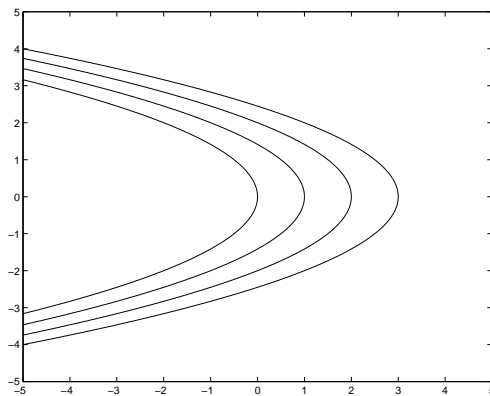

Figure 7.16 Phase plane for $u = -1$. The solution is traveling downwards.

□

SOLUTION 7.12

Since we assume the problem is normal (t_f is free so this is not obvious) we have

$$H = 1 + |u| + \lambda_1 x_2 + \lambda_2 u.$$

Minimization wrt $|u| \leq 1$ gives

$$\lambda_2 > 1 \Rightarrow u = -1$$

$$|\lambda_2| < 1 \Rightarrow u = 0$$

$$\lambda_2 < -1 \Rightarrow u = 1$$

We also have

$$\dot{\lambda}_1 = -H_{x_1} = 0 \Rightarrow \lambda_1 = B$$

$$\dot{\lambda}_2 = -H_{x_2} = -\lambda_1 \Rightarrow \lambda_2 = A - Bt$$

for some constants A, B . If $B < 0$ we see that λ_2 increases (linearly) and hence $u(t)$ passes through the sequence $1 \rightarrow 0 \rightarrow -1$, or a subsequence of this. If $B > 0$ the (sub-) sequence is passed in the other direction $-1 \rightarrow 0 \rightarrow 1$.

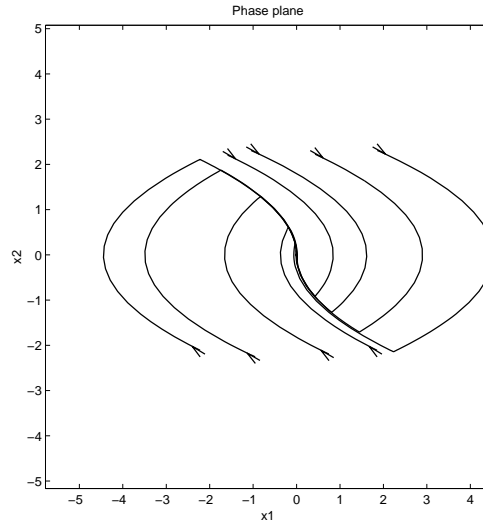

Figure 7.17 Phase plane with switching curve

If $B = 0$ then u is constant: either $u = -1$, $u = 0$ or $u = 1$. The cases $\lambda_2 \equiv 1$ and $\lambda_2 \equiv -1$ are then impossible since the condition $H \equiv 0$ (since t_f is free) then can not be satisfied.

□

SOLUTION 7.13

Alternative 1 Use the Bang-bang theorem (p. 472). Note that (A, B) is controllable and $\Psi_x = \begin{pmatrix} 1 & 0 \\ 0 & 1 \end{pmatrix}$ has full rank, hence $u(t)$ is bang-bang. From “sats 18.6” we know that there are at most $n - 1 = 1$ switches in u (the eigenvalues of A are $-1, -2$ and are hence real).

Alternative 2 Direct calculation shows

$$H = \sigma(t)u + \text{terms independent of } u$$

Minimization wrt u shows that $|u| = 3$ where the sign is given by the sign of $\sigma(t)$. From $\dot{\lambda} = -A^T \lambda$ and $\lambda(t_f) = \Psi_x^T \mu = \mu$ we get

$$\sigma(t) = \lambda^T B = \mu^T e^{-A(t-t_f)} B = c_1 e^{-t} + c_2 e^{-2t}$$

for some constants c_1, c_2 . Since $\sigma(t) = e^{-t}(c_1 + c_2 e^{-t})$ can have at most one sign change and there will be only one switch in u . (It is easy to check that the case $\sigma(t) \equiv 0$ is impossible).

□

SOLUTION 7.14

Hamiltonian.

The objective is to minimize $t_f = \int_0^{t_f} 1 dt$, so $L = 1$ and the Hamiltonian is

$$H = n_0 + \lambda^T (Ax + Bu) = \lambda^T Bu + \lambda^T Ax + n_0$$

Adjoint equation.

$$\dot{\lambda} = -H_x = -A^T \lambda \quad \Rightarrow \quad \lambda(t) = e^{-A^T t} \lambda(0)$$

Optimality conditions.

The optimal control signal must minimize H , so

$$u = -\text{sign}(\lambda(t)^T B) = -\text{sign}(\lambda(0)^T e^{-At} B)$$

When $A = B = 1$, this implies that the optimal input is constant, either $u \equiv 1$ or $u \equiv -1$.

□

SOLUTION 7.15

Minimization of

$$H = (1 + \lambda_1)u$$

gives

$$1 + \lambda_1 \neq 0 \quad : \quad \text{no minimum in } u$$

$$1 + \lambda_1 = 0 \quad : \quad \text{all } u \text{ give minima}$$

This does not prove that all u in fact give minima. It only says that all $u(t)$ are so far possible minima and we need more information.

But in fact since

$$\int_0^1 u dt = \int_0^1 \dot{x}_1 dt = x(1) - x(0) = 1$$

all u that give $x_1(1) = 1$ are minimizers.

□

SOLUTION 7.16

(a) Introduce $x_1 = x$, $x_2 = \dot{x}$

$$\begin{aligned} \dot{x}_1 &= x_2 \\ \dot{x}_2 &= -x_1 + 2x_2^2 + u - 1 \end{aligned} \tag{7.27}$$

(b) Let $\dot{x}_1 = \dot{x}_2 = 0 \Rightarrow (x_1, x_2) = (-1, 0)$ is the only equilibrium. The linearization around this point is

$$A = \begin{bmatrix} 0 & 1 \\ -1 & 4x_2 \end{bmatrix}_{(x_1^0, x_2^0) = (-1, 0)} = \begin{bmatrix} 0 & 1 \\ -1 & 0 \end{bmatrix} \quad B = \begin{bmatrix} 0 \\ 1 \end{bmatrix}$$

The characteristic equation for the linearized system is $s^2 + 1 = 0 \Rightarrow s = \pm i$. We can not conclude stability of the nonlinear system from this.

(c) The simplest way is to cancel the constant term and the nonlinearity with the control signal and introduce some linear feedback.

$$u = +1 - 2\dot{x}^2 - a\dot{x}, \quad a > 0 \Rightarrow \ddot{x} = -a\dot{x} - x$$

As the resulting system is linear and time invariant with poles in the left half plane for all $a > 0$ it is GAS.

□

SOLUTION 7.17

As the hint suggests, the Lyapunov function $V(x_1, x_2, x_3) = \frac{1}{2}(x_1^2 + x_2^2 + x_3^2)$ is used:

$$V(0, 0, 0) = 0, \quad V(x_1, x_2, x_3) > 0 \text{ for } \|x\| \neq 0 \text{ and } V \rightarrow +\infty \text{ as } \|x\| \rightarrow +\infty.$$

$$\begin{aligned} \frac{dV}{dt} &= \dot{x}_1 x_1 + \dot{x}_2 x_2 + \dot{x}_3 x_3 = \\ &= -x_1^2 + x_1 x_2 + x_1 x_3 \tan(x_1) - x_2^4 - x_1 x_2 + x_3 x_2^2 + u x_3 = \\ &= -x_1^2 - x_2^4 + x_3(x_1 \tan(x_1) + x_2^2 + u) \end{aligned} \quad (7.28)$$

By choosing e.g. $u = -x_1 \tan(x_1) - x_2^2 - x_3$ we will get $\frac{dV}{dt} = -x_1^2 - x_2^4 - x_3^2 < 0, \forall x \neq (0, 0, 0)$. Thus, the closed loop system is GAS for this choice of u .

□

SOLUTION 7.18

(a) All singular points are given by $\{\dot{x}_1 = 0, \dot{x}_2 = 0\}$:

$$\begin{aligned} x_1 - x_2 = 0 \text{ and } -3x_1 + x_1^3 - x_2 = 0 &\Rightarrow x_1 = x_2 \text{ and } -4x_1 + x_1^3 = 0 \\ &\text{gives } x_1 = 0, \pm 2 \text{ and } x_2 = x_1 \end{aligned}$$

By writing the system with $u(t) \equiv 0$ and $a = 1$ as $\dot{x} = f(x)$ we get the linearizations at the equilibria as

$$\dot{x} \approx \frac{\partial f}{\partial x} \Big|_{x=x_{eq}} (x - x_{eq})$$

$$A(x_1, x_2) = \frac{\partial f}{\partial x} = \begin{bmatrix} -3 + 3x_1^2 & -1 \\ 1 & -1 \end{bmatrix}$$

$$A(2, 2) = \begin{bmatrix} 9 & -1 \\ 1 & -1 \end{bmatrix}$$

$$\text{eig}(A(2, 2)) = 4 \pm \sqrt{24} \approx \{8.9, -0.9\} \text{ (saddle point)}$$

$A(-2, -2)$ gives the same eigenvalues

$$A(0, 0) = \begin{bmatrix} -3 & -1 \\ 1 & -1 \end{bmatrix}$$

$$\text{eig}(A(0, 0)) = \{-2, -2\} \text{ (stable node)}$$

The origin is only locally asymptotically stable, since there is more than one equilibrium point. Moreover, solutions starting in the two unstable equilibrium points will not converge to the origin.

(b)

$$\dot{V} = x_1 \dot{x}_1 + x_2 \dot{x}_2 = -3x_1^2 + x_1^4 - x_1 x_2 + x_1 x_2 < 0$$

as long as $|x_1| < \sqrt{3}$ and $x_1 \neq 0$. However we see that we can only prove local stability since $\dot{V} = 0$ if $x_1 = 0$. Then we use the invariant set theorem. If we have that $x_1 = 0$ then $\dot{x}_1 = -x_2 \neq 0$ unless x_2 also is 0. Therefore the origin is the only invariant point.

- (c) If $u(x) = -x_1^3$ then all nonlinearities are canceled and the system is purely linear. The eigenvalues are -2,-2 and thus the origin is GAS. This can be showed by using the Lyapunov function as well.

$$\begin{aligned}\dot{V} &= -3x_1^2 + x_1^4 - x_1x_2 + x_1u + x_1x_2 - x_2^2 = -3x_1^2 + x_1(x_1^3 - u) - x_2^2 \\ &= -3x_1^2 - x_2^2 \quad \text{if } u(x) = -x_1^3\end{aligned}$$

Then the origin is globally asymptotically stable, since the Lyapunov function is radially unbounded. The convergence rate is even exponentially since the closed loop system is linear. □

SOLUTION 7.19

Both V_a and V_b are positive definite with respect to (x_1, x_2) and radially unbounded.

(a)

$$\frac{d}{dt}V_a = 2(x_1\dot{x}_1 + x_2\dot{x}_2) = 2(x_1^2 + u)x_2$$

u would need to be $-x_1^2 - f_{odd}(x_2)$ to get the derivative $\frac{dV_a}{dt}$ negative (semi-)definite. As u is bounded this can not be achieved globally.

(b)

$$\frac{d}{dt}V_b = 2\left(\frac{x_1\dot{x}_1}{1+x_1^2} + x_2\dot{x}_2\right) = 2\left(\frac{x_1^2}{1+x_1^2} + u\right)x_2$$

As $0 \leq \frac{x_1^2}{1+x_1^2} \leq 1$ we can always compensate for this term with u and by choosing "the rest of our available control signal" u as for instance $-4\text{sat}(x_2)$, so that $|v| < 5$

$$v = -\frac{x_1^2}{1+x_1^2} - 4\text{sat}(x_2) \Rightarrow u = -\frac{x_1^2}{1+x_1^2} - 4\text{sat}(x_2)$$

However, this will leave us with $\frac{d}{dt}V_b = -4\text{sat}(x_2)x_2 \leq 0$. If $x_2 = 0 \Rightarrow \dot{x}_1 = 0$, but with the chosen control law $\dot{x}_2 = 0$ only if $x_1 = 0$, so the origin will be the only equilibrium. □

SOLUTION 7.20

Consider the system

$$\begin{aligned}\dot{x}_1 &= x_2 - x_1 \\ \dot{x}_2 &= kx_1^2 - x_2 + u\end{aligned}\tag{7.29}$$

where u is the input and k is an unknown coefficient.

We use the Lyapunov function candidate $V(x_1, x_2, \hat{k}) = \frac{1}{2}(x_1^2 + x_2^2 + (k - \hat{k})^2)$, and investigate the time derivative

$$\frac{d}{dt}V(x_1, x_2, \hat{k}) = x_1\dot{x}_1 + x_2\dot{x}_2 - (k - \hat{k})\dot{\hat{k}}$$

since $\dot{k} \sim 0$ because k changes very slowly. Inserting the system equations and some simplifications gives

$$\begin{aligned}\frac{d}{dt}V(x_1, x_2, \hat{k}) &= x_1x_2 - x_1^2 + kx_1^2x_2 - x_2^2 + ux_2 - (k - \hat{k})\dot{k} \\ &= -x_1^2 - x_2^2 + x_1x_2 + ux_2 + k(-\dot{k} + x_1^2x_2) + \hat{k}\dot{k}\end{aligned}$$

If we chose the update law for the estimate as

$$\dot{\hat{k}} = x_1^2x_2 \quad (7.30)$$

we obtain

$$\begin{aligned}\frac{d}{dt}V(x_1, x_2, \hat{k}) &= -x_1^2 - x_2^2 + x_1x_2 + ux_2 + \hat{k}x_1^2x_2 \\ &= -x_1^2 - x_2^2 + x_2(u + x_1 + \hat{k}x_1^2)\end{aligned}$$

which is now independent of the unknown parameter k . We can now proceed as usual with the control design.

Choosing $u = -x_1 - \hat{k}x_1^2$
which gives

$$\frac{d}{dt}V(x_1, x_2, \hat{k}) = -x_1^2 - x_2^2$$

which is negative semi-definite ($V(x_1, x_2, \hat{k})$ does not depend on the estimation error). We can not show asymptotically stability, since we can not guarantee that the estimation error goes to zero. In practice this means that if the system is at rest, the estimation error will not change, even if the estimate is wrong. The estimate is only updated if $x_1, x_2 \neq 0$. This is a general problem for adaptive systems.

□

SOLUTION 7.21

Start with the system $\dot{x}_1 = x_1^2 + \phi(x_1)$ which can be stabilized using $\phi(x_1) = -x_1^2 - x_1$. Notice that $\phi(0) = 0$. Take $V_1(x_1) = x_1^2/2$. To backstep, define

$$z_2 = (x_2 - \phi(x_1)) = x_2 + x_1^2 + x_1,$$

to transfer the system into the form

$$\begin{aligned}\dot{x}_1 &= -x_1 + z_2 \\ \dot{z}_2 &= u + (1 + 2x_1)(-x_1 + z_2)\end{aligned}$$

Taking $V = V_1(x_1) + z_2^2/2$ as a Lyapunov function gives

$$\dot{V} = x_1(-x_1 + z_2) + z_2(u + (1 + 2x_1)(-x_1 + z_2)) = -x_1^2 - z_2^2$$

if $u = u = -(1 + 2x_1)(-x_1 + z_2) - x_1 - z_2$ Hence, the origin is globally asymptotically stable.

□

SOLUTION 7.22

- (a) Start with the system $\dot{x}_1 = x_1^2 - x_1^3 + \phi(x_1)$ which can be stabilized using $\phi(x_1) = -x_1^2 - x_1$. Notice that $\phi(0) = 0$. Take $V_1(x_1) = x_1^2/2$. To backstep, define

$$\zeta_2 = (x_2 - \phi(x_1)) = x_2 + x_1^2 + x_1,$$

to transfer the system into the form

$$\begin{aligned}\dot{x}_1 &= -x_1 - x_1^3 + \zeta_2 \\ \dot{\zeta}_2 &= u + (1 + 2x_1)(-x_1 - x_1^3 + \zeta_2)\end{aligned}$$

Taking $V = V_1(x_1) + \zeta_2^2/2$ as a Lyapunov function gives

$$\dot{V} = x_1(-x_1 - x_1^3 + \zeta_2) + \zeta_2(u + (1 + 2x_1)(-x_1 - x_1^3 + \zeta_2)) = -x_1^2 - x_1^4 - \zeta_2^2$$

if $u = -(1 + 2x_1)(-x_1 + \zeta_2) - x_1 - \zeta_2 = 2x_1^4 - x_1^3 - 2x_1 - 2x_2 - 2x_1x_2$.

Hence, the origin is globally asymptotically stable. Notice that we did not have to cancel out the term $-x_1^3$ since it contributes to stability.

- (b) The phase plane plot of the system is shown in Figure 7.18

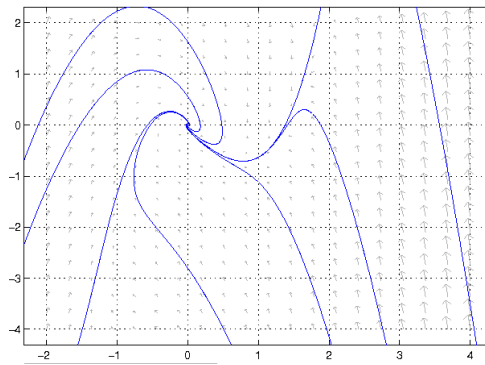

Figure 7.18 Phase plane for system in exercise 7.22.

□

SOLUTION 7.23

- (a) Defining

$$\begin{aligned}f_1(x_1) &= x_1 \\ g_1(x_1) &= 1 \\ f_2(x_1, x_2) &= \sin(x_1 - x_2) \\ g_2(x_1, x_2) &= 1\end{aligned}$$

the system can be written on the strict feedback form

$$\begin{aligned}\dot{x}_1 &= f_1(x_1) + g_1(x_1)x_2 \\ \dot{x}_2 &= f_2(x_1, x_2) + g_2(x_1, x_2)u\end{aligned}$$

(see lecture 8).

- (b) Start with the system $\dot{x}_1 = x_1 + \phi(x_1)$ which can be stabilized using $\phi(x_1) = -2x_1$. Notice that $\phi(0) = 0$. Take $V_1(x_1) = x_1^2/2$. To backstep, define

$$\zeta_2 = (x_2 - \phi(x_1)) = x_2 + 2x_1,$$

to transfer the system into the form

$$\begin{aligned}\dot{x}_1 &= -x_1 + \zeta_2 \\ \dot{\zeta}_2 &= -2x_1 + 2\zeta_2 + \sin(3x_1 - \zeta_2) + u\end{aligned}$$

Taking $V = V_1(x_1) + \zeta_2^2/2$ as a Lyapunov function gives

$$\begin{aligned}\dot{V} &= x_1\dot{x}_1 + \zeta_2\dot{\zeta}_2 = x_1(-x_1 + \zeta_2) + \zeta_2(u - 2x_1 + 2\zeta_2 + \sin(3x_1 - \zeta_2)) \\ &= -x_1^2 - \zeta_2^2\end{aligned}$$

if $u = -\sin(3x_1 - \zeta_2) + x_1 - 3\zeta_2 = -\sin(x_1 - x_2) - 5x_1 - 3x_2$. Hence, the origin is globally asymptotically stable. □

SOLUTION 7.24

- (a) Defining

$$\begin{aligned}f_1(x_1) &= -\text{sat}(x_1) \\ g_1(x_1) &= x_1^2 \\ f_2(x_1, x_2) &= x_1^2 \\ g_2(x_1, x_2) &= 1\end{aligned}$$

the system can be written on the strict feedback form

$$\begin{aligned}\dot{x}_1 &= f_1(x_1) + g_1(x_1)x_2 \\ \dot{x}_2 &= f_2(x_1, x_2) + g_2(x_1, x_2)u\end{aligned}$$

(see lecture 8).

- (b) Start with the system $\dot{x}_1 = -\text{sat}(x_1) + x_1^2\phi(x_1)$ which can be stabilized using $\phi(x_1) = -x_1$. Notice that $\phi(0) = 0$. Take $V_1(x_1) = x_1^2/2$. To backstep, define

$$\zeta_2 = (x_2 - \phi(x_1)) = x_2 + x_1,$$

to transfer the system into the form

$$\begin{aligned}\dot{x}_1 &= -\text{sat}(x_1) - x_1^3 + x_1^2\zeta_2 \\ \dot{\zeta}_2 &= -\text{sat}(x_1) - x_1^3 + x_1^2\zeta_2 + x_1^2 + u\end{aligned}$$

Notice that we did not have to cancel out the term $-\text{sat}(x_1)$ since it contributes to stability.

Taking $V = V_1(x_1) + \zeta_2^2/2$ as a Lyapunov function gives

$$\begin{aligned}\dot{V} &= -x_1\text{sat}(x_1) - x_1^4 + x_1^3\zeta_2 + \zeta_2(-\text{sat}(x_1) - x_1^3 + x_1^2\zeta_2 + x_1^2 + u) \\ &= -x_1\text{sat}(x_1) - x_1^4 + \zeta_2(-\text{sat}(x_1) + x_1^2\zeta_2 + x_1^2 + u) \\ &= -x_1\text{sat}(x_1) - x_1^4 - \zeta_2^2\end{aligned}$$

if $u = \text{sat}(x_1) - x_1^2\zeta_2 - x_1^2 - \zeta_2 = \text{sat}(x_1) - x_1^3 - x_1^2 - x_1 - x_2 - x_1^2x_2$. Hence, the origin is globally asymptotically stable.

□

SOLUTION 7.25

Start with the system $\dot{x}_1 = x_1 + \phi_1(x_1)$ which can be stabilized using $\phi_1(x_1) = -2x_1$. Notice that $\phi_1(0) = 0$. Take $V_1(x_1) = x_1^2/2$. To backstep, define

$$\zeta_2 = (x_2 - \phi_1(x_1)) = x_2 + 2x_1,$$

to transfer the system into the form

$$\begin{aligned}\dot{x}_1 &= -x_1 + \zeta_2 \\ \dot{\zeta}_2 &= -2x_1 + 2\zeta_2 + \sin(3x_1 - \zeta_2) + x_3\end{aligned}$$

Think of x_3 as a control input and consider the system

$$\begin{aligned}\dot{x}_1 &= -x_1 + \zeta_2 \\ \dot{\zeta}_2 &= -2x_1 + 2\zeta_2 + \sin(3x_1 - \zeta_2) + \phi_2\end{aligned}$$

and use the Lyapunov function candidate $V_2 = V_1 + \zeta_2^2/2$:

$$\begin{aligned}\dot{V}_2 &= x_1\dot{x}_1 + \zeta_2\dot{\zeta}_2 = x_1(-x_1 + \zeta_2) + \zeta_2(-2x_1 + 2\zeta_2 + \sin(-x_1 + 2\zeta_2) + \phi_2) \\ &= -x_1^2 - \zeta_2^2 + \zeta_2 \underbrace{(-x_1 + 3\zeta_2 + \sin(3x_1 - \zeta_2) + \phi_2)}\end{aligned}$$

which is stabilized by

$$\begin{aligned}\phi_2 &= -\sin(3x_1 - \zeta_2) + x_1 - 3\zeta_2 \\ &\Downarrow \\ \dot{V}_2 &= -x_1^2 - \zeta_2^2\end{aligned}$$

To backstep a second time, define

$$\begin{aligned}\zeta_3 &= x_3 - \phi_2 = x_3 + \sin(3x_1 - \zeta_2) - x_1 + 3\zeta_2 \\ &\implies \\ \dot{\zeta}_3 &= \dot{x}_3 + \cos(3x_1 - \zeta_2) \cdot (3\dot{x}_1 - \dot{\zeta}_2) - (\dot{x}_1 + 3\dot{\zeta}_2) \\ &= u + \cos(3x_1 - \zeta_2)(-2x_1 + 4\zeta_2 - \zeta_3) - 2x_1 - 4\zeta_2 + 3\zeta_3\end{aligned}$$

to transfer the system into the form

$$\begin{aligned}\dot{x}_1 &= -x_1 + \zeta_2 \\ \dot{\zeta}_2 &= -x_1 - \zeta_2 + \zeta_3 \\ \dot{\zeta}_3 &= u + \cos(3x_1 - \zeta_2)(-2x_1 + 4\zeta_2 - \zeta_3) - 2x_1 - 4\zeta_2 + 3\zeta_3 \\ &= u + \beta(x, z)\end{aligned}$$

Now the control signal appears in the equation, and we can design a control law. Consider the Lyapunov function candidate $V = V_2 + \zeta_3^2/2$:

$$\begin{aligned}\dot{V} &= x_1\dot{x}_1 + \zeta_2\dot{\zeta}_2 + \zeta_3\dot{\zeta}_3 \\ &= x_1(-x_1 + \zeta_2) + \zeta_2(-x_1 - \zeta_2 + \zeta_3) + \zeta_3(u + \beta(x_1, \zeta_2, \zeta_3)) \\ &= -x_1^2 - \zeta_2^2 - \zeta_3^2 + \zeta_3 \underbrace{(\zeta_2 + \zeta_3 + u + \beta(x_1, \zeta_2, \zeta_3))}\end{aligned}$$

Choosing

$$u = -\zeta_2 - \zeta_3 - \beta = \cos(3x_1 - \zeta_2)(-2x_1 + 4\zeta_2 - \zeta_3) + 2x_1 + 3\zeta_2 - 4\zeta_3$$

gives

$$\dot{V} = -x_1^2 - \zeta_2^2 - \zeta_3^2$$

which is negative definite, and the system is therefore global asymptotically stable

□

SOLUTION 7.26

See solution in link or in lecture slides.

□

SOLUTION 7.27

The Hamiltonian-Jacobi-Bellman equation for this problem is

$$V_t(t, x) = -\min_u [L + \nabla_x V f] \Leftrightarrow \dot{q}x^2 = -\min_u [x^2u^2 + 2qx^2u] = -\min_u [u^2 + 2qu]x^2$$

Minimization yields $u = -q$. Insertion gives

$$\dot{q}x^2 = -(q^2 - 2q^2)x^2 = q^2x^2 \Leftrightarrow \dot{q} = q^2$$

Solving the differential equation yields $q = \frac{1}{C-t}$, where C is a constant. It remains to determine C . For this, we use that the final "cost-to-go" is given by

$$V(1, x) = \Phi(x) = x^2 \Leftrightarrow q(1)x^2 = x^2 \Leftrightarrow q(1) = 1.$$

This yields $C = 2$. Since $u = -q$, the optimal control is $u(t, x) = \frac{1}{t-2}$.

□

8. Bibliography

Åström, K. J. (1968): *Reglerteknik – Olinjära System*. TLTH/VBV.

Boyd, S. P. (1997): “Homework assignments in ee375 – advanced analysis of feedback.” Available from <http://www-leland.stanford.edu/class/ee375/>.

Khalil, H. K. (1996): *Nonlinear Systems*, 2nd edition. Prentice Hall, Upper Saddle River, N.J.

Slotine, J.-J. E. and W. LI (1991): *Applied Nonlinear Control*. Prentice Hall, Englewood Cliffs, N.J.