

Lecture 2

- Lyapunov theory *cont'd.*
- Storage function and dissipation
- Absolute stability
- The Kalman-Yakubovich-Popov lemma
- Circle Criterion
- Popov Criterion

Invariant Sets

Definition A set M is called **invariant** if for the system

$$\dot{x} = f(x),$$

$x(0) \in M$ implies that $x(t) \in M$ for all $t \geq 0$.

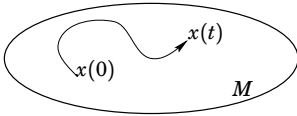

Example – saturated control

Exercise - 5 min (revisited)

Find a bounded control signal $u = \text{sat}(v)$, which **globally** stabilizes the system

$$\begin{aligned} \dot{x}_1 &= x_1 x_2 \\ \dot{x}_2 &= u \\ u &= \text{sat}(v(x_1, x_2)) \end{aligned} \quad (1)$$

Hint: Use the Lyapunov function candidate

$$V_2 = \ln(1 + x_1^2) + \alpha x_2^2$$

for some appropriate value of α .

With this type of control law, we end up with

$$\dot{V} = -q(x_2) \leq 0$$

for some $q(\cdot)$ which only depends on the state x_2 .

$E = \{x | q(x) = 0\}$, i. e., E is the line $x_2 = 0$.

Can solutions stay on that line?

$\dot{x}_2 = 0$ only for also $x_1 = 0$ (insert control law and check) so the solution curves will not stay on the line $x_2 = 0$ except for the origin. Thus, the origin is the largest invariant set and asymptotic stability follows from the invariant set theorem.

Consider

$$\dot{x} = f(x), \quad f(0) = 0, \quad f(x) \neq 0, \quad \forall x \neq 0$$

and

$$A = \frac{\partial f}{\partial x}$$

$$\text{If } \boxed{A + A^T < 0} \quad \forall x \neq 0$$

then use $V = f(x)^T f(x) > 0, \forall x \neq 0$,

$$\begin{aligned} \dot{V} &= f^T \dot{f} + \dot{f}^T f \\ &= \left\{ f = \frac{\partial f}{\partial x} \dot{x} = Af \right\} \\ &= f^T \{A + A^T\} f < 0, \quad \forall x \neq 0 \end{aligned}$$

See more general case in [Khalil, Exercise 4.10]

Invariant Set Theorem

Theorem Let $\Omega \in \mathbf{R}^n$ be a bounded and closed set that is invariant with respect to

$$\dot{x} = f(x).$$

Let $V : \mathbf{R}^n \rightarrow \mathbf{R}$ be a radially unbounded C^1 function such that $\dot{V}(x) \leq 0$ for $x \in \Omega$. Let E be the set of points in Ω where $\dot{V}(x) = 0$. If M is the largest invariant set in E , then every solution with $x(0) \in \Omega$ approaches M as $t \rightarrow \infty$ (see proof in textbook)

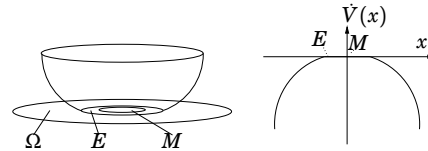

Common use is to try to show that the origin is the largest invariant set of E , ($M = \{0\}$).

$$V_2 = \ln(1 + x_1^2) + \alpha x_2^2 / 2$$

$$\dot{V}_2 = 2 \frac{x_1 \dot{x}_1}{1 + x_1^2} + 2\alpha x_2 \dot{x}_2$$

$$= 2x_2 \left(\underbrace{\frac{x_1^2}{1 + x_1^2}}_{0 \leq \dots < 1} + \alpha \text{sat}(v) \right)$$

Can use some part to cancel $\frac{x_1^2}{1+x_1^2}$ and some to add bounded negative damping in x_2 (like $\text{sign}(x_2)$ or $\text{sat}(x_2)$ or ...)

Invariant sets - nonautonomous systems

Problems with invariant sets for nonautonomous systems.

$$\dot{V} = \frac{\partial V}{\partial t} + \frac{\partial V}{\partial x} f(t, x) \text{ depends both on } t \text{ and } x.$$

Barbalat's Lemma - nonautonomous systems

Let $\phi : \mathbb{R} \rightarrow \mathbb{R}$ be a uniformly continuous function on $[0, \infty)$.
Suppose that

$$\lim_{t \rightarrow \infty} \int_0^t \phi(\tau) d\tau$$

exists and is finite. Then

$$\phi(t) \rightarrow 0 \text{ as } t \rightarrow \infty$$

Common tool in adaptive control.

- ▶ $V(t, x)$ is lower bounded
- ▶ $\dot{V}(t, x) \leq 0$
- ▶ $\dot{V}(t, x)$ uniformly cont. in time

then $\dot{V}(t, x) \rightarrow 0$ as $t \rightarrow \infty$

Nonautonomous systems —cont'd

[Khalil, Theorem 4.8 & 4.9]

Assume there exists $V(t, x)$ such that

$$\underbrace{W_1(x)}_{\text{positive definite}} \leq V(t, x) \leq \underbrace{W_2(x)}_{\text{decrecent}}$$

$$\dot{V}(t, x) = \frac{\partial V}{\partial t} + \frac{\partial V}{\partial x} f(t, x) \leq -W_3(x)$$

W_3 is a continuous positive **semi**-definite function.

Solutions to $\dot{x} = f(t, x)$ starting in $x(t_0) \in \{x \in B_r | \dots\}$ are bounded and satisfy

$$W_3(x(t)) \rightarrow 0 \text{ as } t \rightarrow \infty$$

See example in Khalil.

Exercise - 5 min [Slotine]

Consider the system

$$\begin{aligned} \dot{x}_1 &= x_1^2 + x_2^3 \\ \dot{x}_2 &= -x_2 + x_1^3 \end{aligned}$$

Use Chetaev's theorem to show that the origin is an unstable equilibrium point.

You may consider

$$V = x_1 - x_2^2/2$$

for a certain region.

Example—Capacitor

A capacitor

$$i = C \frac{du}{dt}$$

is dissipative with respect to the supply rate $r(t) = i(t)u(t)$.

A storage function is

$$S(u) = \frac{Cu^2}{2}$$

In fact

$$\frac{Cu(t_0)^2}{2} + \int_{t_0}^{t_1} i(t)u(t)dt = \frac{Cu(t_1)^2}{2}$$

Remark: In many adaptive control cases we have a Lyapunov function candidate depending on states and parameter errors, while the time-derivative of the candidate function only depends on the states.

An instability result - Chetaev's Theorem

Idea: show that a solution arbitrarily close to the origin have to leave.

Let $f(0) = 0$ and let $V : D \rightarrow \mathbb{R}$ be a continuously differentiable function on a neighborhood D of $x = 0$, such that $V(0) = 0$. Suppose that the set

$$U = \{x \in D : \|x\| < r, V(x) > 0\}$$

is nonempty for every $r > 0$. If $\dot{V} > 0$ in U , then $x = 0$ is unstable.

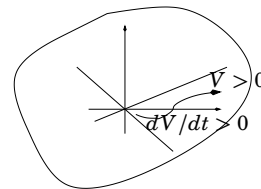

Dissipativity

Consider a nonlinear system

$$\begin{cases} \dot{x}(t) = f(x(t), u(t), t), & t \geq 0 \\ y(t) = h(x(t), u(t), t) \end{cases}$$

and a locally integrable function

$$r(t) = r(u(t), y(t), t).$$

The system is said to be *dissipative* with respect to the *supply rate* r if there exists a *storage function* $S(t, x)$ such that for all t_0, t_1 and inputs u on $[t_0, t_1]$

$$S(t_0, x(t_0)) + \int_{t_0}^{t_1} r(t)dt \geq S(t_1, x(t_1)) \geq 0$$

Example—Inductance

An inductance

$$u = L \frac{di}{dt}$$

is dissipative with respect to the supply rate $r(t) = i(t)u(t)$.

A storage function is

$$S(i) = \frac{Li^2}{2}$$

In fact

$$\frac{Li(t_0)^2}{2} + \int_{t_0}^{t_1} i(t)u(t)dt = \frac{Li(t_1)^2}{2}$$

Memoryless Nonlinearity

The memoryless nonlinearity $w = \phi(v, t)$ with sector condition

$$\alpha \leq \phi(v, t)/v \leq \beta, \quad \forall t \geq 0, v \neq 0$$

is dissipative with respect to the quadratic supply rate

$$r(t) = -[w(t) - \alpha v(t)][w(t) - \beta v(t)]$$

with storage function

$$S(t, x) \equiv 0$$

Storage function as Lyapunov function

For a system without input, suppose that

$$r(y) \leq -k|x|^c$$

for some $k > 0$. Then the dissipation inequality implies

$$S(t_0, x(t_0)) - \int_{t_0}^{t_1} k|x(t)|^c dt \geq S(t_1, x(t_1))$$

which is an integrated form of the Lyapunov inequality

$$\frac{d}{dt} S(t, x(t)) \leq -k|x|^c$$

Global Sector Condition

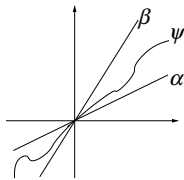

Let $\psi(t, y) \in \mathbf{R}$ be piecewise continuous in $t \in [0, \infty)$ and locally Lipschitz in $y \in \mathbf{R}$.

Assume that ψ satisfies the *global sector condition*

$$\alpha \leq \psi(t, y)/y \leq \beta, \quad \forall t \geq 0, y \neq 0 \quad (2)$$

The Circle Criterion

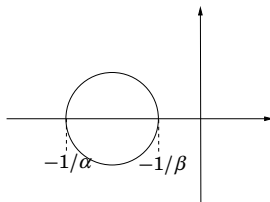

The system (3) with sector condition (2) is absolutely stable if the origin is asymptotically stable for $\psi(t, y) = \alpha y$ and the Nyquist plot

$$C(j\omega I - A)^{-1}B + D, \quad \omega \in \mathbf{R}$$

does not intersect the closed disc with diameter $[-1/\alpha, -1/\beta]$.

Linear System Dissipativity

The linear system

$$\dot{x}(t) = Ax(t) + Bu(t), \quad t \geq 0$$

is dissipative with respect to the supply rate

$$-\begin{bmatrix} x \\ u \end{bmatrix}^T M \begin{bmatrix} x \\ u \end{bmatrix}$$

and storage function $x^T P x$ if and only if

$$M + \begin{bmatrix} A^T P + PA & PB \\ B^T P & 0 \end{bmatrix} \geq 0$$

Interconnection of dissipative systems

If the two systems

$$\dot{x}_1 = f_1(x_1, u_1) \quad \dot{x}_2 = f_2(x_2, u_2)$$

are dissipative with supply rates $r_1(u_1, x_1)$ and $r_2(u_2, x_2)$ and storage functions $S(x_1)$, $S(x_2)$, then their interconnection

$$\begin{cases} \dot{x}_1 = f_1(x_1, h_2(x_2)) \\ \dot{x}_2 = f_2(x_2, h_1(x_1)) \end{cases}$$

is dissipative with respect to every supply rate of the form

$$\tau_1 r_1(h_2(x_2), x_1) + \tau_2 r_2(h_1(x_1), x_2) \quad \tau_1, \tau_2 \geq 0$$

The corresponding supply rate is

$$\tau_1 S_1(x_1) + \tau_2 S_2(x_2)$$

Absolute Stability

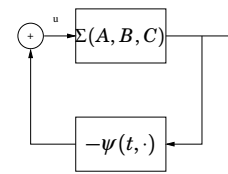

The system

$$\begin{cases} \dot{x} = Ax + Bu, & t \geq 0 \\ y = Cx \\ u = -\psi(t, y) \end{cases} \quad (3)$$

with sector condition (2) is called *absolutely stable* if the origin is globally uniformly asymptotically stable for any nonlinearity ψ satisfying (2).

Loop Transformation

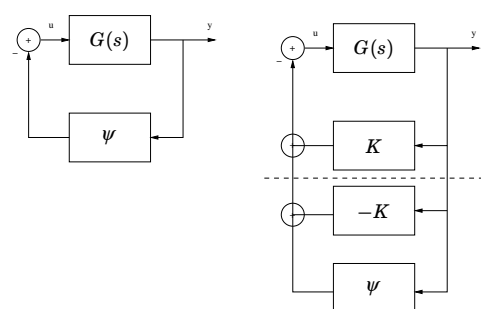

Common choices: $K = \alpha$ or $K = \frac{\alpha + \beta}{2}$

Special Case: Positivity

Let $M(j\omega) = C(j\omega I - A)^{-1}B + D$, where A is Hurwitz. The system

$$\begin{cases} \dot{x} = Ax + Bu, & t \geq 0 \\ y = Cx + Du \\ u = -\psi(t, y) \end{cases}$$

with sector condition

$$\psi(t, y)/y \geq 0 \quad \forall t \geq 0, y \neq 0$$

is absolutely stable if

$$M(j\omega) + M(j\omega)^* > 0, \quad \forall \omega \in [0, \infty)$$

Note: For SISO systems this means that the Nyquist curve lies strictly in the right half plane.

The Kalman-Yakubovich-Popov Lemma

- Exists in numerous versions
- Idea: **Frequency dependence** is replaced by **matrix equations/inequalities** or vice versa ¹

¹Yakubovich in Lund: –"Yesterday, Ulf told me that nowadays we mostly use it the other way round!"

Compare Khalil (5.10-12):

M is strictly positive real if and only if $\exists P, W, L, \epsilon$:

$$\begin{bmatrix} PA + A^T P & PB - C^T \\ B^T P - C & D + D^T \end{bmatrix} = - \begin{bmatrix} \epsilon P + L^T L & L^T W \\ W^T L & W^T W \end{bmatrix}$$

Mini-version a la [Slotine & Li]:

$$\begin{aligned} \dot{x} &= Ax + bu, & A \text{ Hurwitz, (i. e., } \operatorname{Re}\{\lambda_i(A)\} < 0\} \\ y &= cx \end{aligned}$$

The following statements are equivalent

- $\operatorname{Re}\{c(j\omega I - A)^{-1}b\} > 0, \forall \omega \in [0, \infty)$
- There exist $P = P^T > 0$ and $Q = Q^T > 0$ such that

$$\begin{aligned} A^T P + PA &= -Q \\ Pb &= c^T \end{aligned}$$

The K-Y-P Lemma, version II - cont.

- (i) $\Phi(j\omega)^* \tilde{\Phi}(j\omega) + \tilde{\Phi}(j\omega)^* \Phi(j\omega) \leq 0$ for all $\omega \in \mathbf{R}$ with $\det(j\omega \tilde{A} - A) \neq 0$.
- (ii) There exists a nonzero pair $(p, P) \in \mathbf{R} \times \mathbf{R}^{n \times n}$ such that $p \geq 0, P = P^*$ and

$$\begin{aligned} & \begin{bmatrix} A & B \\ C & D \end{bmatrix}^* \begin{bmatrix} P & 0 \\ 0 & pI \end{bmatrix} \begin{bmatrix} \tilde{A} & \tilde{B} \\ \tilde{C} & \tilde{D} \end{bmatrix} \\ & + \begin{bmatrix} \tilde{A} & \tilde{B} \\ \tilde{C} & \tilde{D} \end{bmatrix}^* \begin{bmatrix} P & 0 \\ 0 & pI \end{bmatrix} \begin{bmatrix} A & B \\ C & D \end{bmatrix} \leq 0 \end{aligned}$$

The corresponding equivalence for strict inequalities holds with $p = 1$.

Proof

Set

$$V(x) = x^T P x, \quad P = P^T > 0$$

$$\begin{aligned} \Rightarrow \dot{V} &= 2x^T P \dot{x} \\ &= 2x^T P \begin{bmatrix} A & B \\ -\psi \end{bmatrix} \begin{bmatrix} x \\ -\psi \end{bmatrix} \leq 2x^T P \begin{bmatrix} A & B \\ -\psi \end{bmatrix} \begin{bmatrix} x \\ -\psi \end{bmatrix} + 2\psi y \\ &= 2 \begin{bmatrix} x^T & -\psi \end{bmatrix} \begin{bmatrix} P & 0 \\ 0 & I \end{bmatrix} \begin{bmatrix} A & B \\ -C & -D \end{bmatrix} \begin{bmatrix} x \\ -\psi \end{bmatrix} \end{aligned}$$

By the Kalman-Yakubovich-Popov Lemma, the inequality $M(j\omega) + M(j\omega)^* > 0$ guarantees that P can be chosen to make the upper bound for \dot{V} strictly negative for all $(x, \psi) \neq (0, 0)$.

Stability by Lyapunov's theorem.

The K-Y-P Lemma, version I

Let $M(j\omega) = C(j\omega I - A)^{-1}B + D$, where A is Hurwitz. Then the following statements are equivalent.

- (i) $M(j\omega) + M(j\omega)^* > 0$ for all $\omega \in [0, \infty)$
- (ii) $\exists P = P^T > 0$ such that

$$\begin{bmatrix} P & 0 \\ 0 & I \end{bmatrix} \begin{bmatrix} A & B \\ C & D \end{bmatrix} + \begin{bmatrix} A & B \\ C & D \end{bmatrix}^T \begin{bmatrix} P & 0 \\ 0 & I \end{bmatrix} < 0$$

The K-Y-P Lemma, version II

For

$$\begin{bmatrix} \Phi(s) \\ \tilde{\Phi}(s) \end{bmatrix} = \begin{bmatrix} C \\ \tilde{C} \end{bmatrix} (s\tilde{A} - A)^{-1} (B - s\tilde{B}) + \begin{bmatrix} D \\ \tilde{D} \end{bmatrix},$$

with $s\tilde{A} - A$ nonsingular for some $s \in \mathbf{C}$, the following two statements are equivalent.

Some Notation Helps

Introduce

$$\begin{aligned} M &= \begin{bmatrix} A & B \end{bmatrix}, & \tilde{M} &= \begin{bmatrix} I & 0 \end{bmatrix}, \\ N &= \begin{bmatrix} C & D \end{bmatrix}, & \tilde{N} &= \begin{bmatrix} 0 & I \end{bmatrix}. \end{aligned}$$

Then

$$y = [C(j\omega I - A)^{-1}B + D]u$$

if and only if

$$\begin{bmatrix} y \\ u \end{bmatrix} = \begin{bmatrix} N \\ \tilde{N} \end{bmatrix} w$$

for some $w \in \mathbf{C}^{n+m}$ satisfying $Mw = j\omega \tilde{M}w$.

Lemma 1

Given $y, z \in \mathbf{C}^n$, there exists an $\omega \in [0, \infty)$ such that $y = j\omega z$, if and only if $yz^* + zy^* = 0$.

Proof Necessity is obvious. For sufficiency, assume that $yz^* + zy^* = 0$. Then

$$|v^*(y+z)|^2 - |v^*(y-z)|^2 = 2v^*(yz^* + zy^*)v = 0.$$

Hence $y = \lambda z$ for some $\lambda \in \mathbf{C} \cup \{\infty\}$. The equality $yz^* + zy^* = 0$ gives that λ is purely imaginary.

(i) and (ii) can be connected by the following sequence of equivalent statements.

(a) $w^*(\tilde{N}^*N + N^*\tilde{N})w < 0$ for $w \neq 0$ satisfying

$$Mw = j\omega\tilde{M}w \text{ with } \omega \in \mathbf{R}.$$

(b) $\Theta \cap \mathcal{P} = \emptyset$, where

$$\Theta = \left\{ \left(w^*(\tilde{N}^*N + N^*\tilde{N})w, \tilde{M}ww^*M^* + Mww^*\tilde{M}^* \right) : w^*w = 1 \right\}$$

$$\mathcal{P} = \{(r, 0) : r > 0\}$$

(c) $(\text{conv } \Theta) \cap \mathcal{P} = \emptyset$.

(d) There exists a hyperplane in $\mathbf{R} \times \mathbf{R}^{n \times n}$ separating Θ from \mathcal{P} , i.e. $\exists P$ such that $\forall w \neq 0$

$$0 > w^* \left(\tilde{N}^*N + N^*\tilde{N} + M^*P\tilde{M} + \tilde{M}^*PM \right) w$$

The Popov Criterion

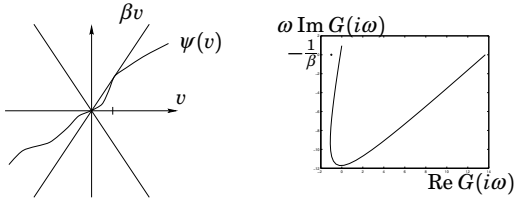

Suppose that $\psi : \mathbf{R} \rightarrow \mathbf{R}$ is Lipschitz and $0 \leq \psi(v)/v \leq \beta$. Let $G(i\omega) = C(i\omega I - A)^{-1}B$ with A Hurwitz and (A, B, C) minimal. If there exists $\eta \in \mathbf{R}$ such that

$$\text{Re} [(1 + i\omega\eta)G(i\omega)] > -\frac{1}{\beta} \quad \omega \in \mathbf{R} \quad (4)$$

then the differential equation $\dot{x}(t) = Ax(t) - B\psi(Cx(t))$ is exponentially stable.

Popov proof II

For $\eta \geq 0$, $V > 0$ is obvious for $x \neq 0$.

Stability for linear ψ gives $V \rightarrow 0$ and $\dot{V} < 0$, so V must be positive also for $\eta < 0$.

Stability for nonlinear ψ from Lyapunov's theorem.

Proof of the K-Y-P Lemma

See handout (Rantzer)

Time-invariant Nonlinearity

Let $\psi(y) \in \mathbf{R}$ be locally Lipschitz in $y \in \mathbf{R}$.

Assume that ψ satisfies the global sector condition

$$\alpha \leq \psi(y)/y \leq \beta, \quad \forall t \geq 0, y \neq 0$$

Popov proof I

Set

$$V(x) = x^T P x + 2\eta\beta \int_0^{Cx} \psi(\sigma) d\sigma$$

where P is an $n \times n$ positive definite matrix. Then

$$\begin{aligned} \dot{V} &= 2(x^T P + \eta\beta\psi C)\dot{x} \\ &= 2(x^T P + \eta\beta\psi C) \begin{bmatrix} A & B \\ -\psi \end{bmatrix} \begin{bmatrix} x \\ -\psi \end{bmatrix} \\ &\leq 2(x^T P + \eta\beta\psi C) \begin{bmatrix} A & B \\ -\psi \end{bmatrix} \begin{bmatrix} x \\ -\psi \end{bmatrix} - 2\psi(\psi - \beta y) \\ &= 2 \begin{bmatrix} x^T & -\psi \end{bmatrix} \begin{bmatrix} PA & PB \\ -\beta C - \eta\beta CA & -1 - \eta\beta CB \end{bmatrix} \begin{bmatrix} x \\ -\psi \end{bmatrix} \end{aligned}$$

By the K-Y-P Lemma there is a P that makes the upper bound for \dot{V} strictly negative for all $(x, \psi) \neq (0, 0)$.

The Kalman-Yakubovich-Popov lemma – III

Given $A \in \mathbf{R}^{n \times n}$, $B \in \mathbf{R}^{n \times m}$, $M = M^T \in \mathbf{R}^{(n+m) \times (n+m)}$, with $i\omega I - A$ nonsingular for $\omega \in \mathbf{R}$ and (A, B) controllable, the following two statements are equivalent.

(i)

$$\begin{bmatrix} (i\omega I - A)^{-1}B \\ I \end{bmatrix}^* M \begin{bmatrix} (i\omega I - A)^{-1}B \\ I \end{bmatrix} \leq 0 \quad \forall \omega \in \mathbf{R}$$

(ii) There exists a matrix $P \in \mathbf{R}^{n \times n}$ such that $P = P^*$ and

$$M + \begin{bmatrix} A^T P + PA & PB \\ B^T P & 0 \end{bmatrix} \leq 0$$

(ii) \Rightarrow (i) simple

Multiply from right and left by $\begin{bmatrix} (i\omega I - A)^{-1}B \\ I \end{bmatrix}$

(i) \Rightarrow (ii) difficult

- ▶ Spectral factorization (Anderson)
- ▶ Linear quadratic optimization (Yakubovich)
- ▶ Find $(1, P)$ as separating hyperplane between the sets

$$\left\{ \left(\begin{bmatrix} x \\ u \end{bmatrix}^T M \begin{bmatrix} x \\ u \end{bmatrix}, x(Ax + Bu)^* + (Ax + Bu)x^* \right) : (x, u) \in \mathbf{C}^{n+m} \right\}$$

$$\{(r, 0) : r \geq 0\}$$
